

ASSEMBLY INSTRUCTIONS

INSTRUCCIONES DE MONTAJE / INSTRUCTIONS DE MONTAGE

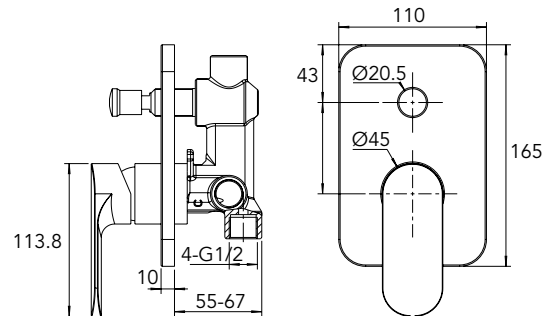

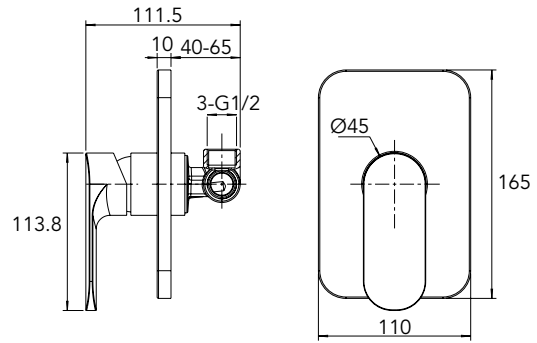

IMPORTANT NOTE_CLEANING THE FAUCETS / NOTA IMPORTANTE_ LIMPIEZA DE LA GRIFERÍA / NOTE IMPORTANTE_ NETTOYER LES ROBINETS

- Cleaning products may lead to further damage of certain surfaces.
- Do not mix cleaning products under no circumstances as they may give off harmful gases.
- Do not use rough cloths, abrasive cleaners, bleachers or whiteners with chlorine.
- Use only specific cleaners or the ones advised by the manufacturer for each surface and finishes.

·Los productos de limpieza pueden empeorar el deterioro de ciertas superficies.
 ·Se aconseja que no mezcle en ningún caso productos de limpieza ya que pueden emitir gases tóxicos.
 ·No emplee en la limpieza tejidos rugosos, limpiadores abrasivos ni lejías o blanqueadores con cloro.
 ·Utilice únicamente limpiadores específicos o aconsejados por el fabricante para cada superficie y acabado.

·Les produits de nettoyage peuvent endommager certaines surfaces.
 ·Jamais mélanger les produits de nettoyage car ils peuvent dégager des gaz nocifs.
 ·N'utilisez pas de chiffons rugueux, de nettoyeurs abrasifs, lessive ou blanchisseurs avec du chlore.
 ·N'utilisez que des nettoyeurs spécifiques ou ceux recommandés par le fabricant pour chaque surface et chaque finition.

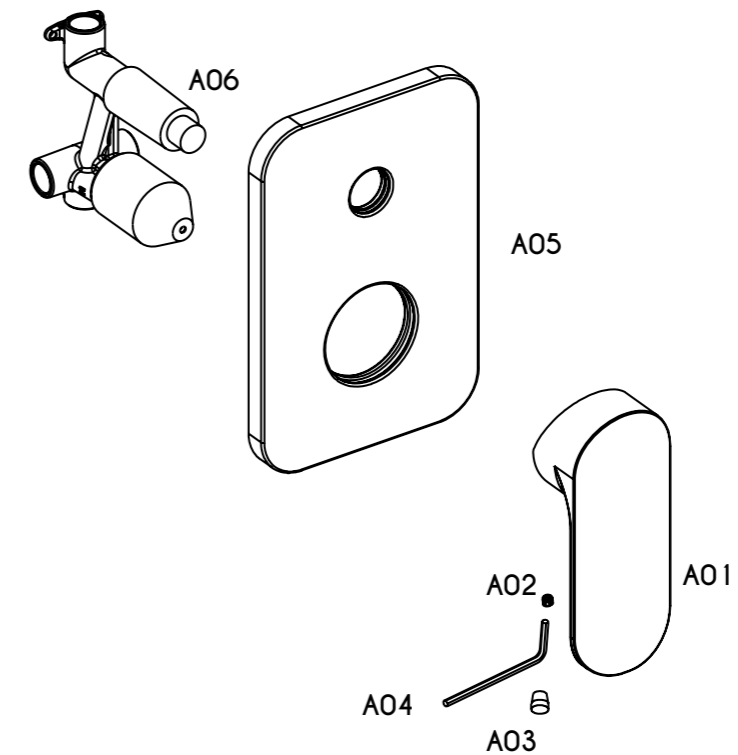
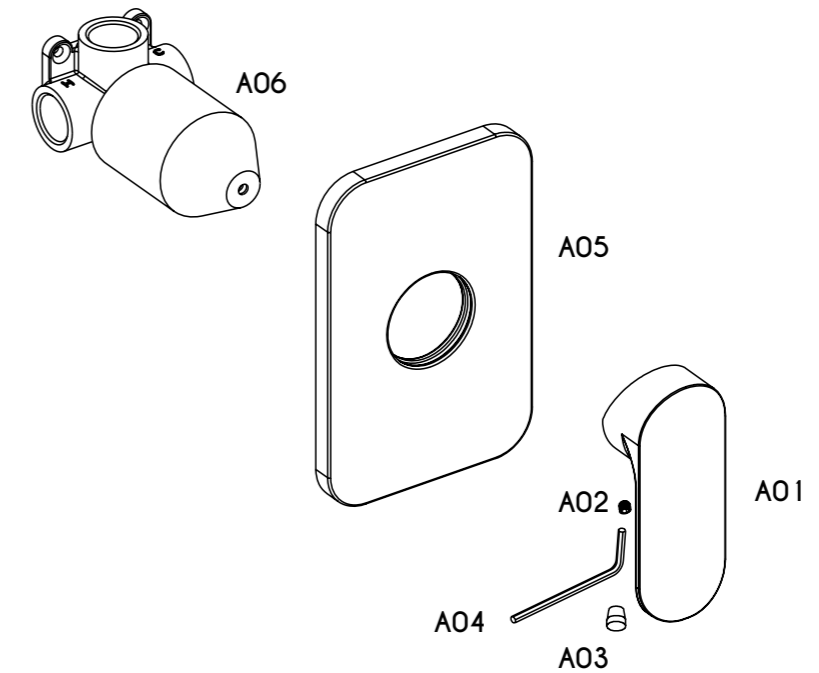

FLOW PRO

MONOMANDO ENCASTRE DE DUCHA
CONCEALED SHOWER MIXER /
MITIGEUR DOUCHE ENCASTRÉ

FUTUR^{BATH}

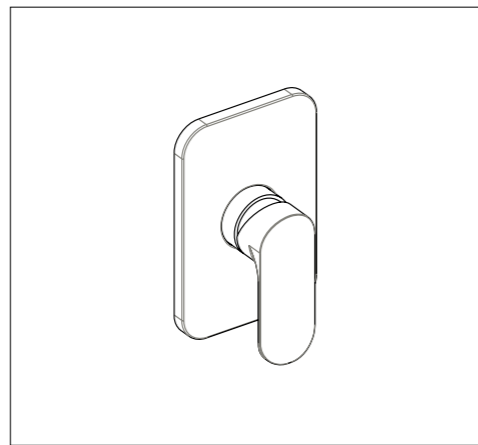
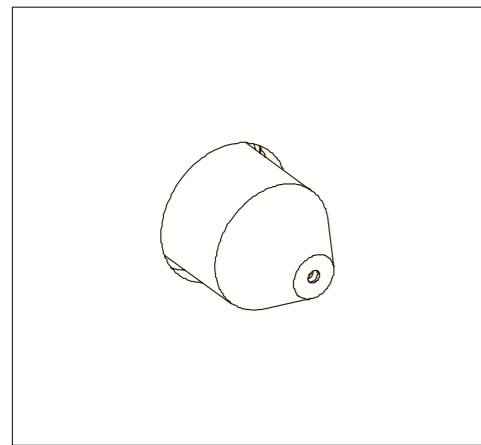
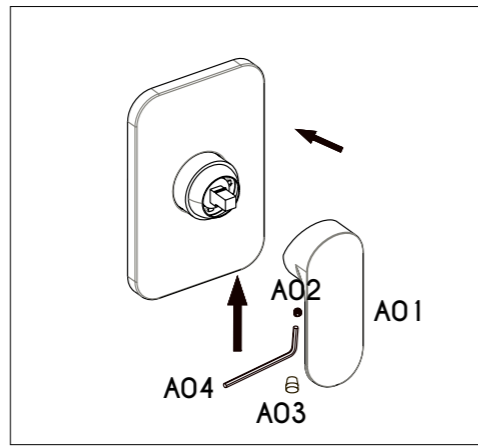
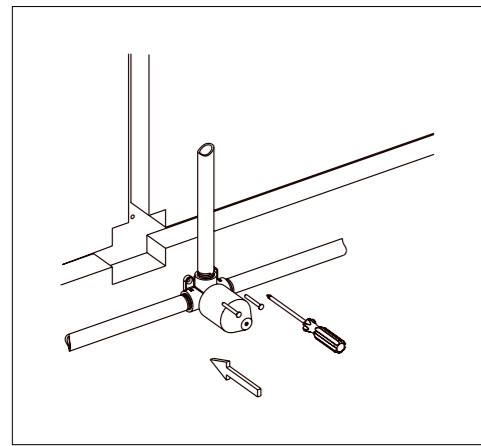
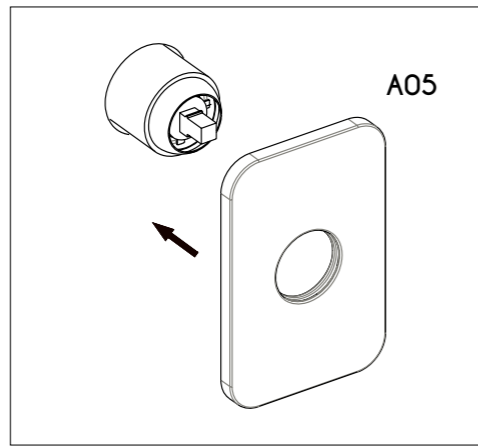
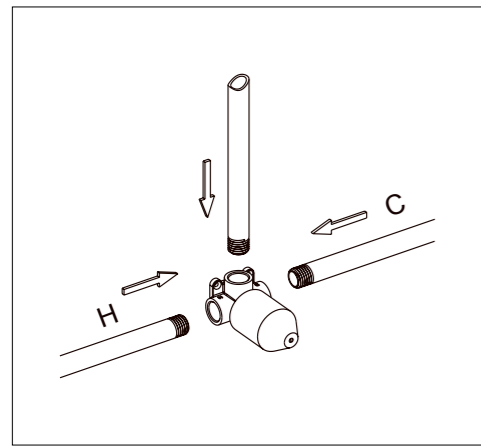
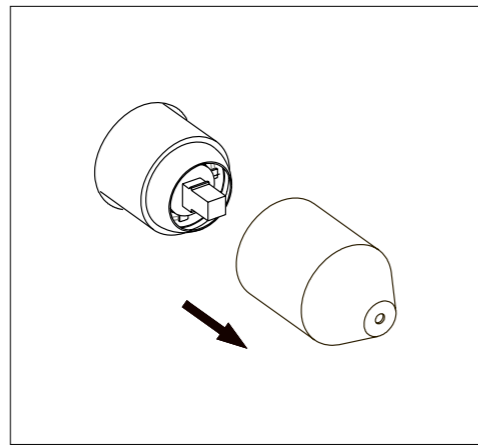
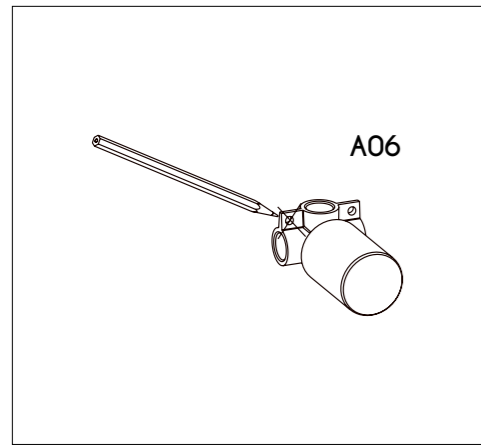

FLOW PRO

MONOMANDO ENCASTRE DE DUCHA
CONCEALED SHOWER MIXER /
MITIGEUR DOUCHE ENCASTRÉ

FUTUR^{BATH}

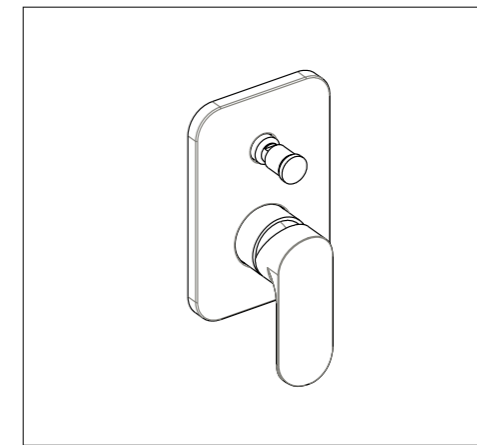
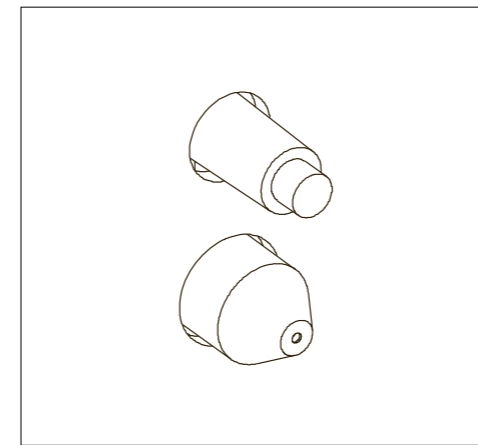
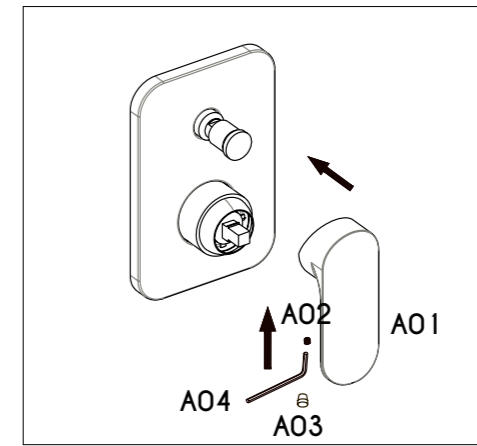
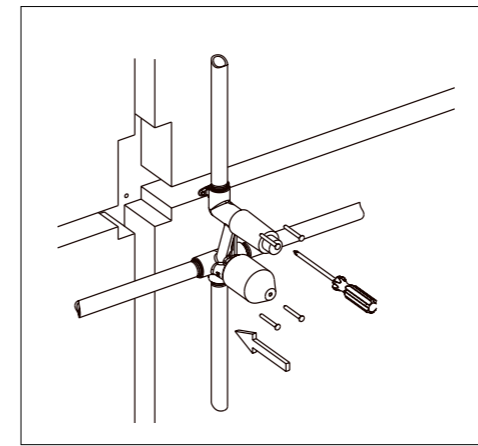
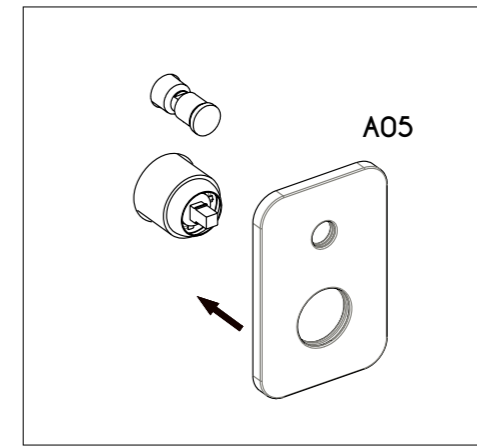
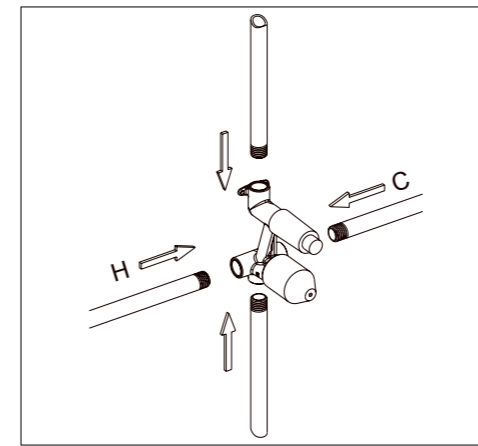
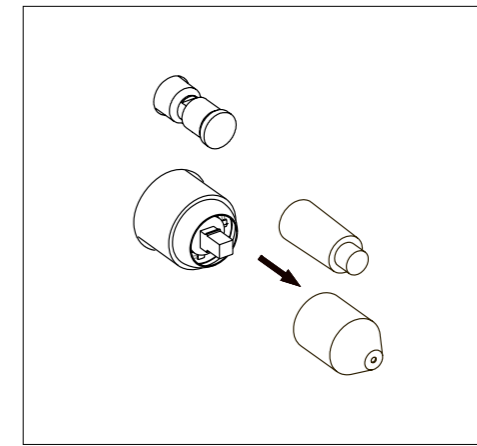
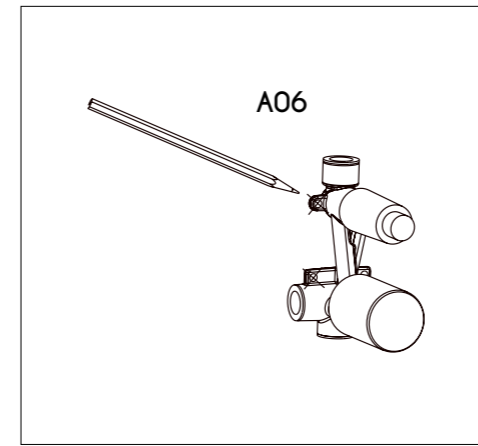

FUTUR BATH

www.futurbath.com

ASSEMBLY INSTRUCTIONS

INSTRUCCIONES DE MONTAJE / INSTRUCTIONS DE MONTAGE

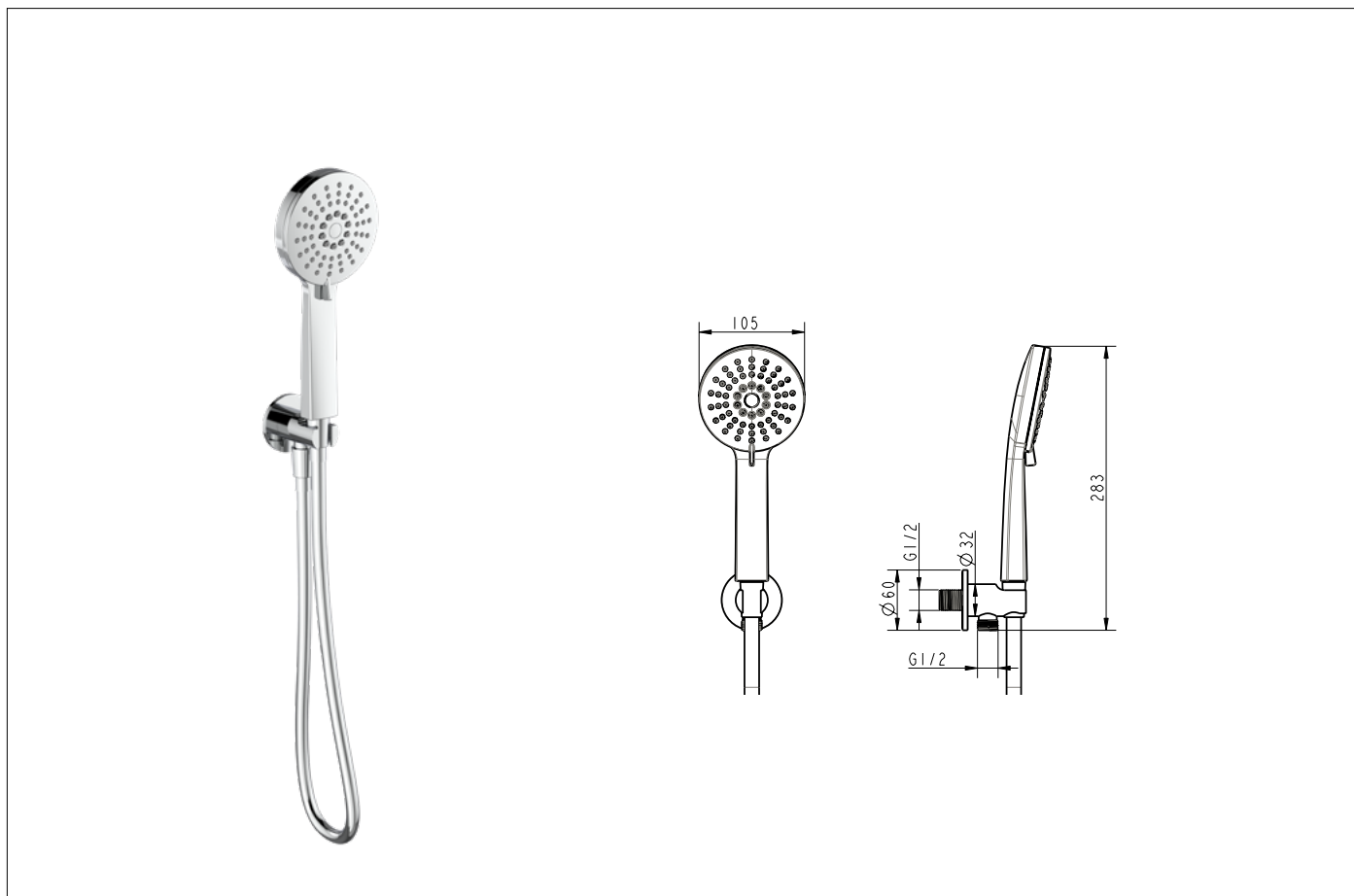



IMPORTANT NOTE_CLEANING THE FAUCETS / NOTA IMPORTANTE_ LIMPIEZA DE LA GRIFERÍA / NOTE IMPORTANTE_ NETTOYER LES ROBINETS

- Cleaning products may lead to further damage of certain surfaces.
- Do not mix cleaning products under no circumstances as they may give off harmful gases.
- Do not use rough cloths, abrasive cleaners, bleachers or whiteners with chlorine.
- Use only specific cleaners or the ones advised by the manufacturer for each surface and finishes.

·Los productos de limpieza pueden empeorar el deterioro de ciertas superficies.

·Se aconseja que no mezcle en ningún caso productos de limpieza ya que pueden emitir gases tóxicos.

·No emplee en la limpieza tejidos rugosos, limpiadores abrasivos ni lejías o blanqueadores con cloro.

·Utilice únicamente limpiadores específicos o aconsejados por el fabricante para cada superficie y acabado.

·Les produits de nettoyage peuvent endommager certaines surfaces. ·Jamais mélanger les produits de nettoyage car ils peuvent dégager des gaz nocifs.

·N'utilisez pas de chiffons rugueux, de nettoyeurs abrasifs, lessive ou blanchisseurs avec du chlore.

·N'utilisez que des nettoyeurs spécifiques ou ceux recommandés par le fabricant pour chaque surface et chaque finition.

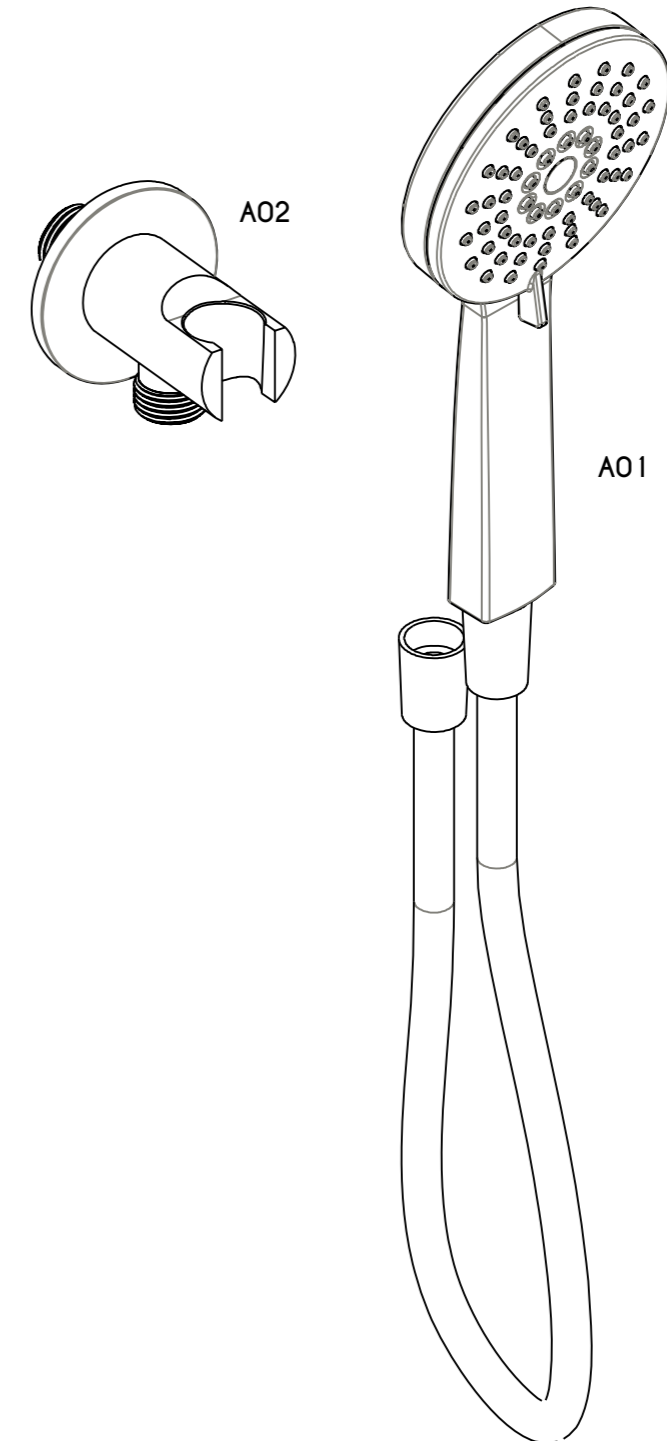

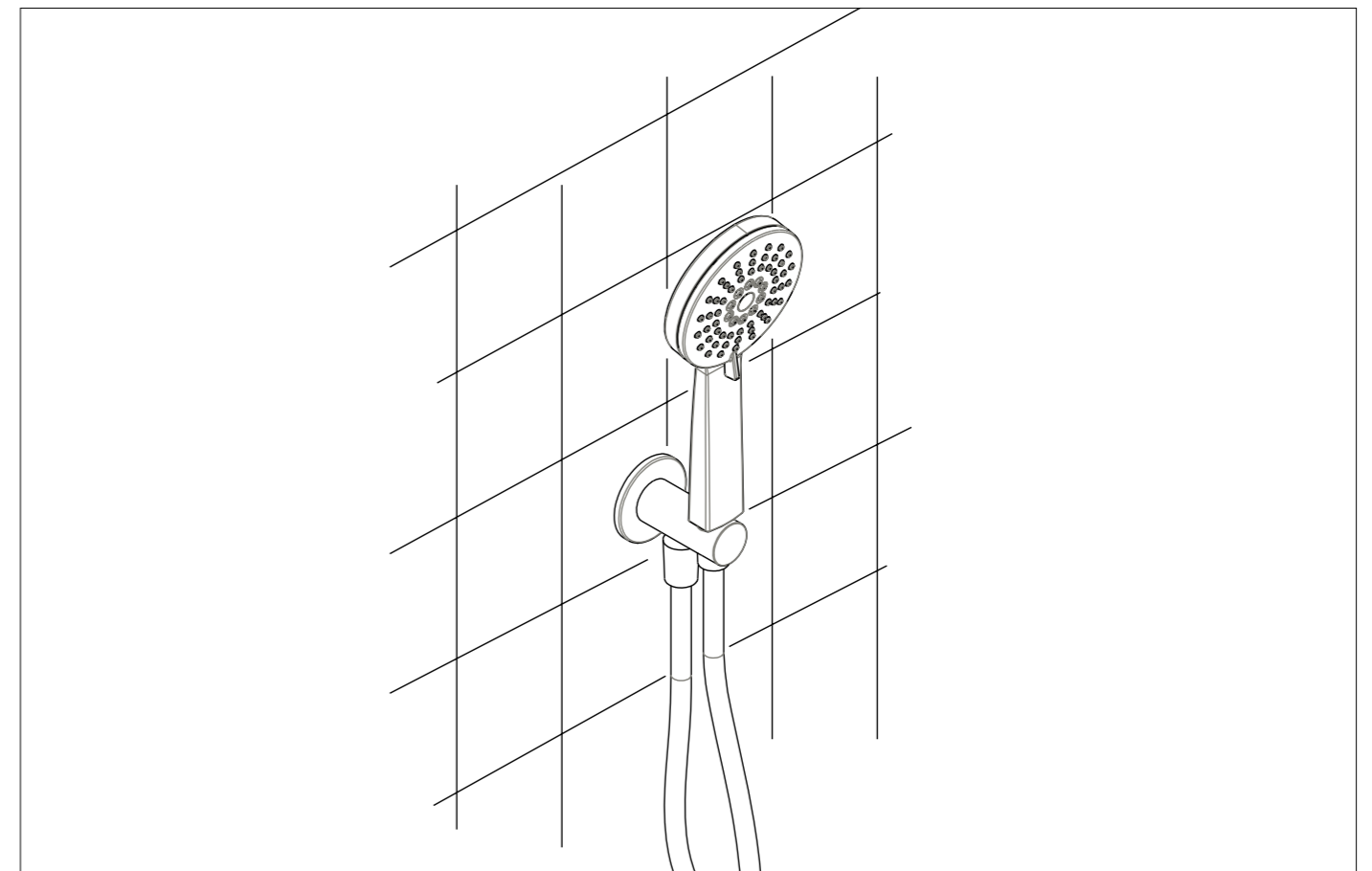
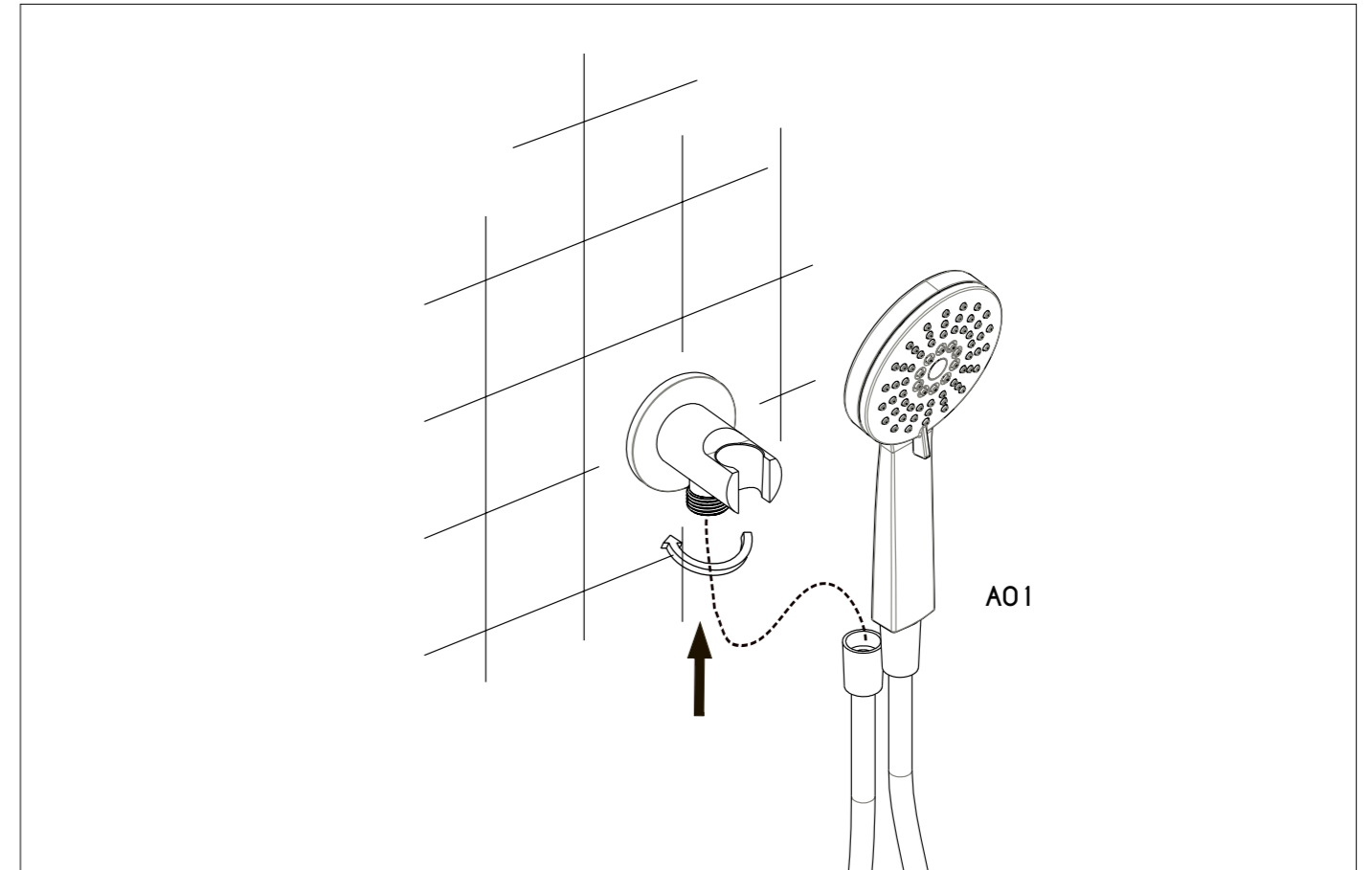
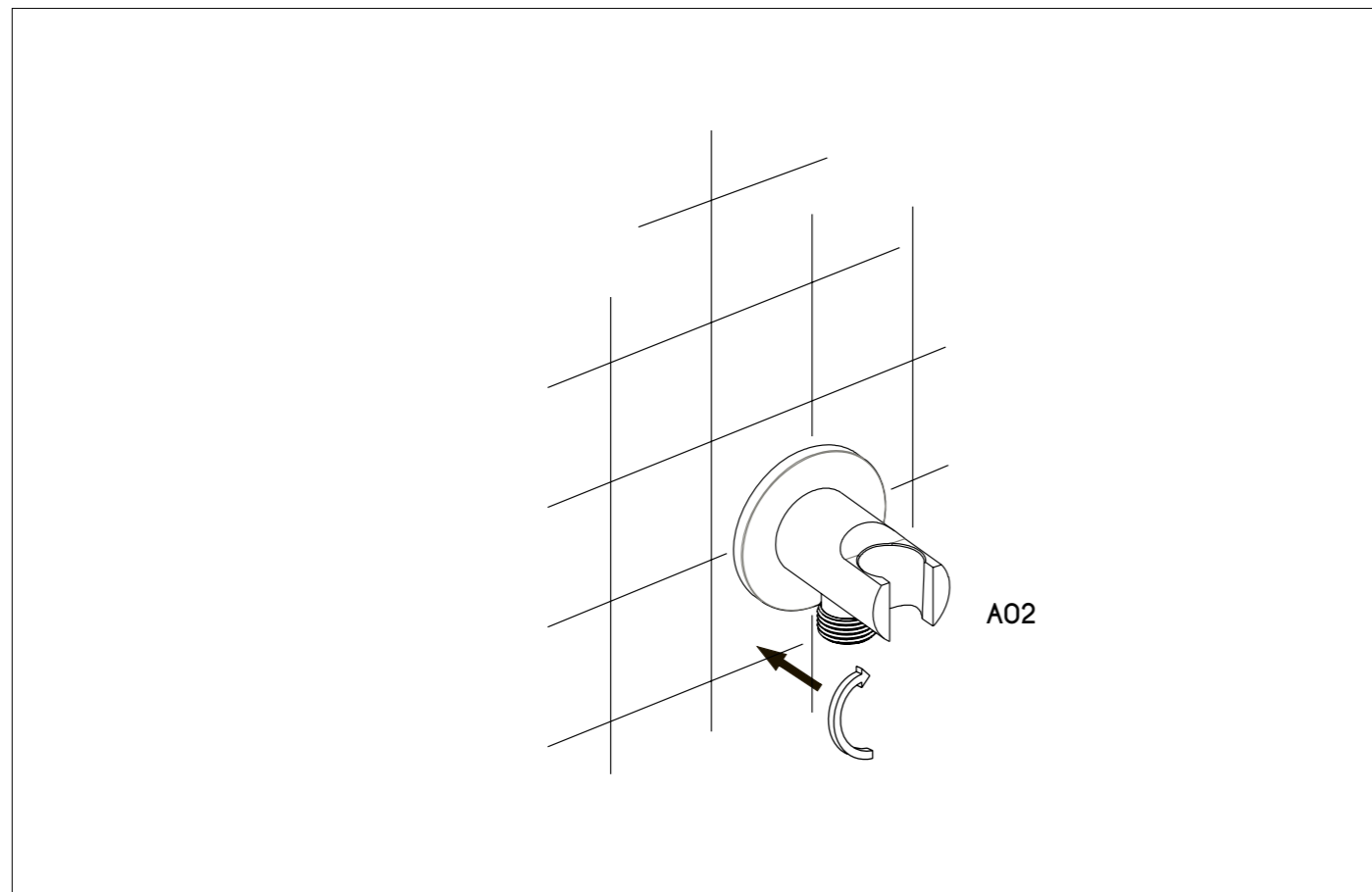
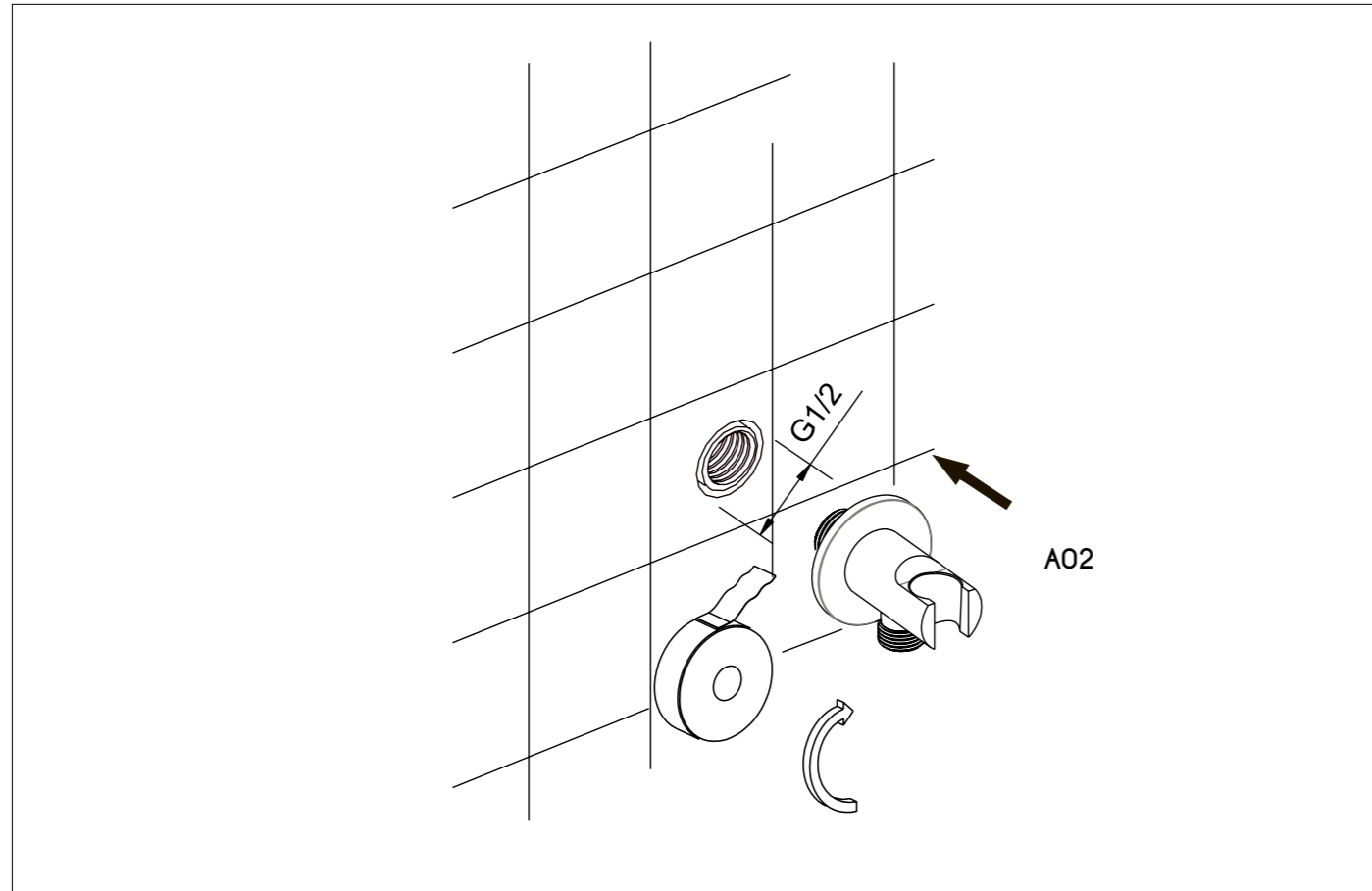

FUTUR BATH

www.futurbath.com

ASSEMBLY INSTRUCTIONS

INSTRUCCIONES DE MONTAJE / INSTRUCTIONS DE MONTAGE

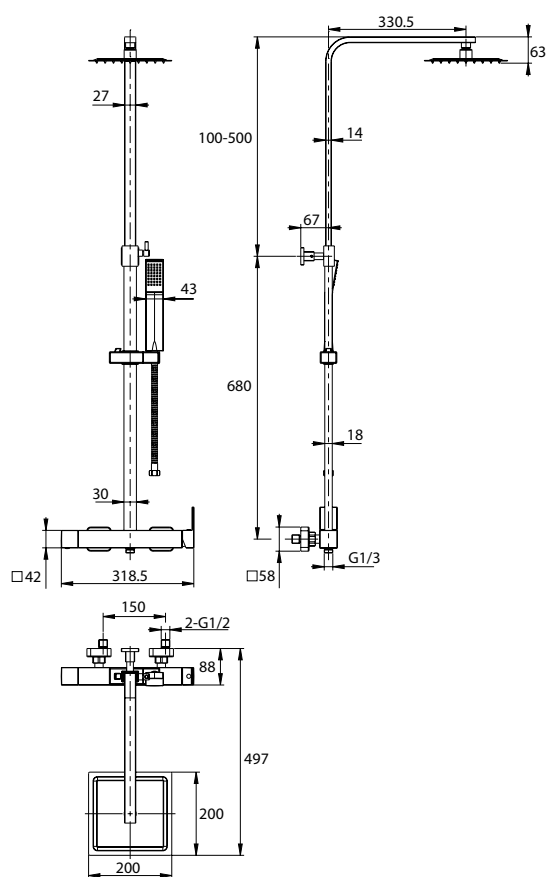



IMPORTANT NOTE_CLEANING THE FAUCETS / NOTA IMPORTANTE_ LIMPIEZA DE LA GRIFERÍA / NOTE IMPORTANTE_ NETTOYER LES ROBINETS

- Cleaning products may lead to further damage of certain surfaces.
- Do not mix cleaning products under no circumstances as they may give off harmful gases.
- Do not use rough cloths, abrasive cleaners, bleachers or whiteners with chlorine.
- Use only specific cleaners or the ones advised by the manufacturer for each surface and finishes.

·Los productos de limpieza pueden empeorar el deterioro de ciertas superficies.
·Se aconseja que no mezcle en ningún caso productos de limpieza ya que pueden emitir gases tóxicos.
·No emplee en la limpieza tejidos rugosos, limpiadores abrasivos ni lejías o blanqueadores con cloro.
·Utilice únicamente limpiadores específicos o aconsejados por el fabricante para cada superficie y acabado.

·Les produits de nettoyage peuvent endommager certaines surfaces.
·Jamais mélanger les produits de nettoyage car ils peuvent dégager des gaz nocifs.
·N'utilisez pas de chiffons rugueux, de nettoyeurs abrasifs, lessive ou blanchisseurs avec du chlore.
·N'utilisez que des nettoyeurs spécifiques ou ceux recommandés par le fabricant pour chaque surface et chaque finition.

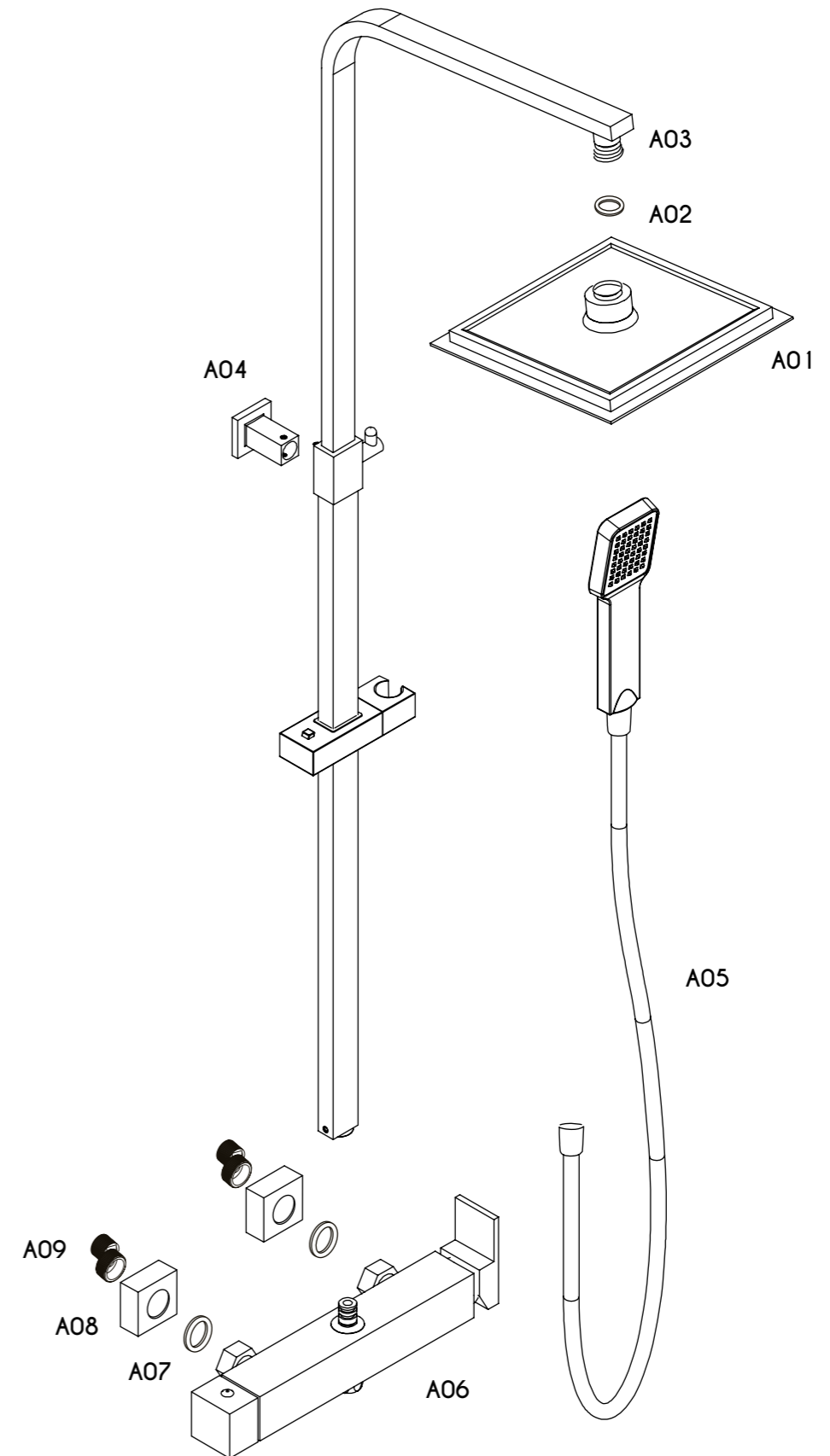

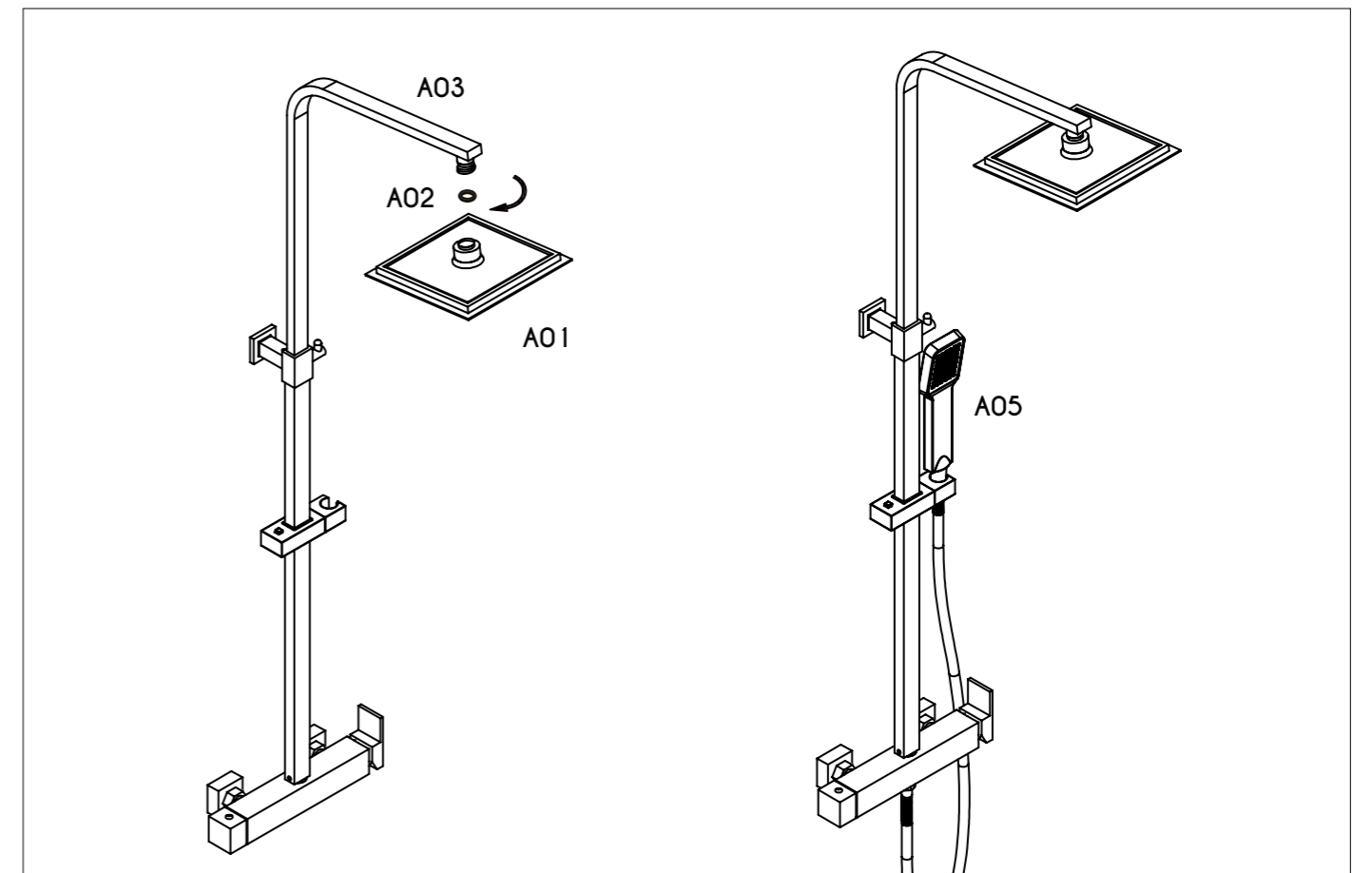
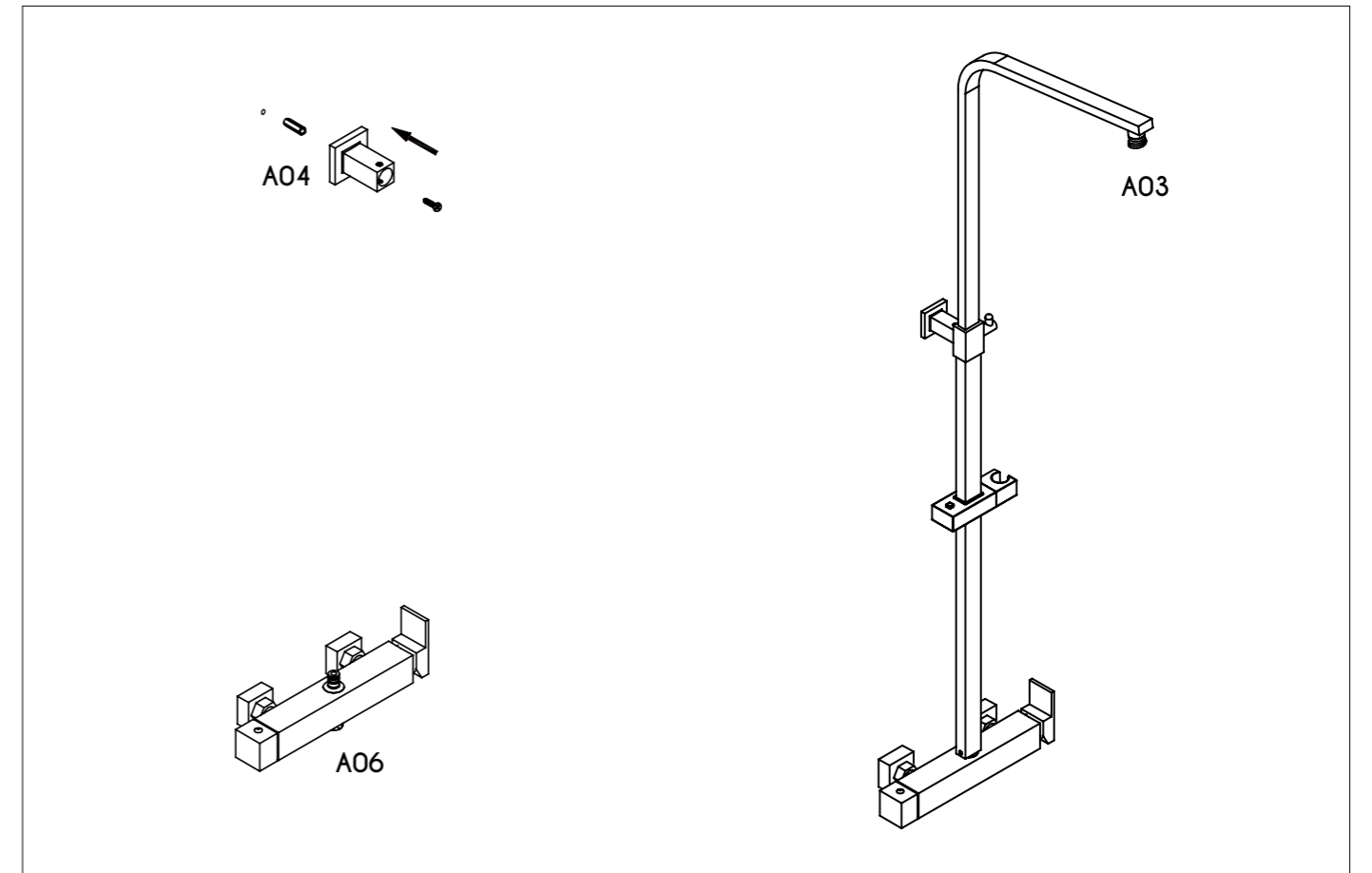
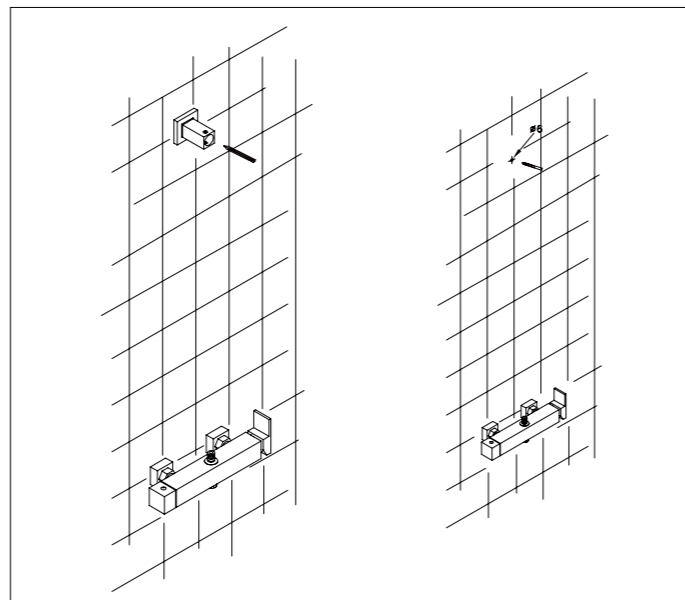
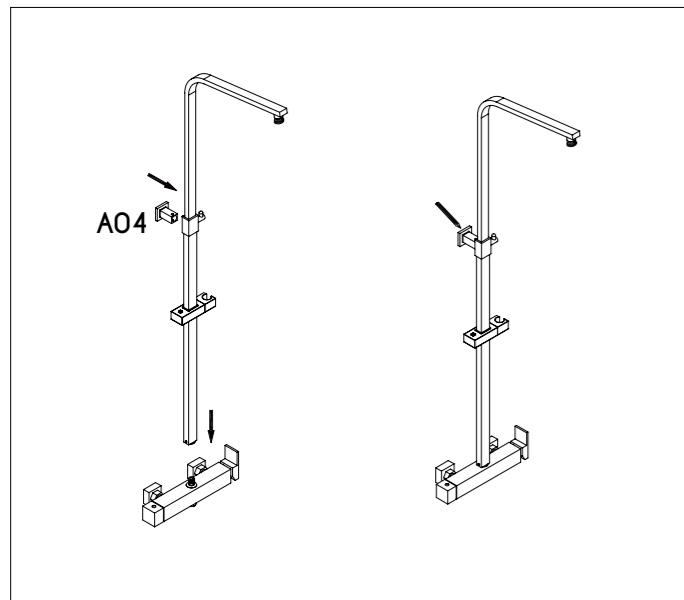
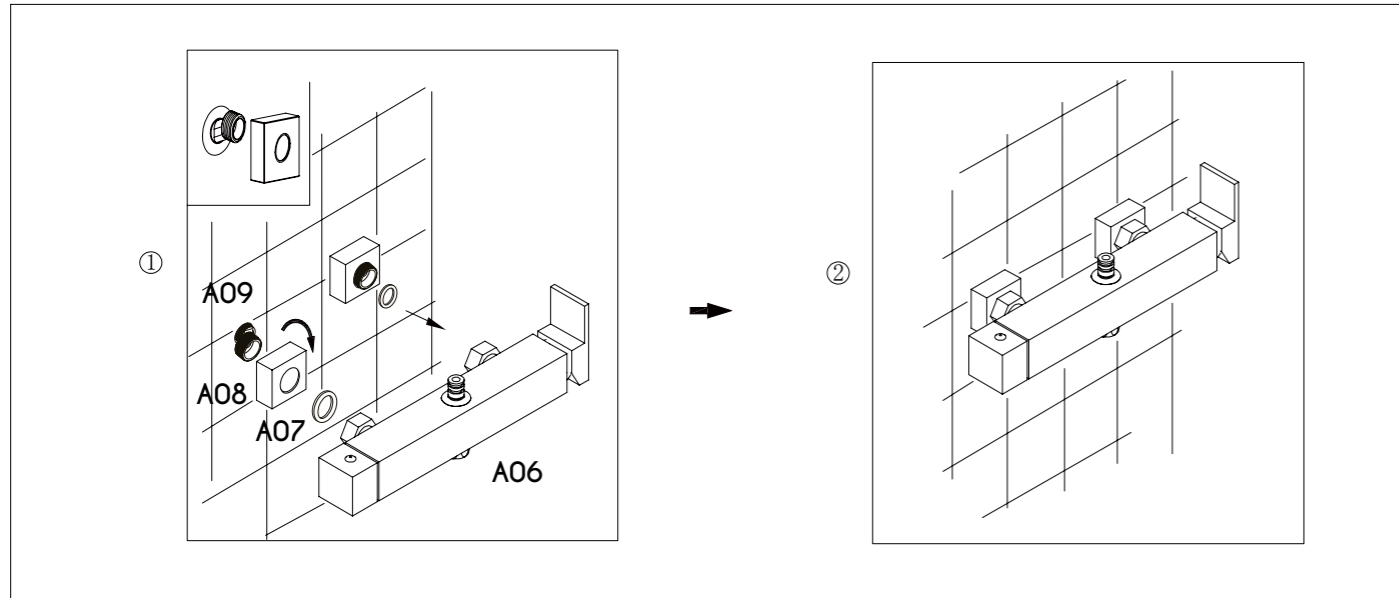
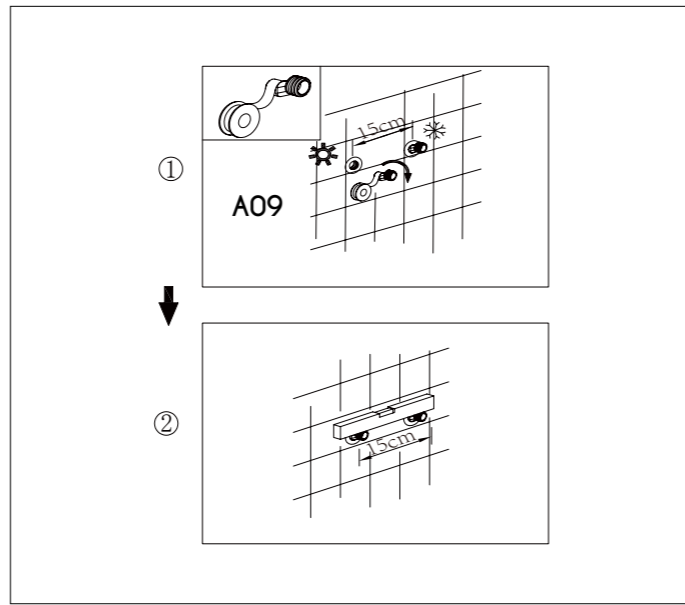
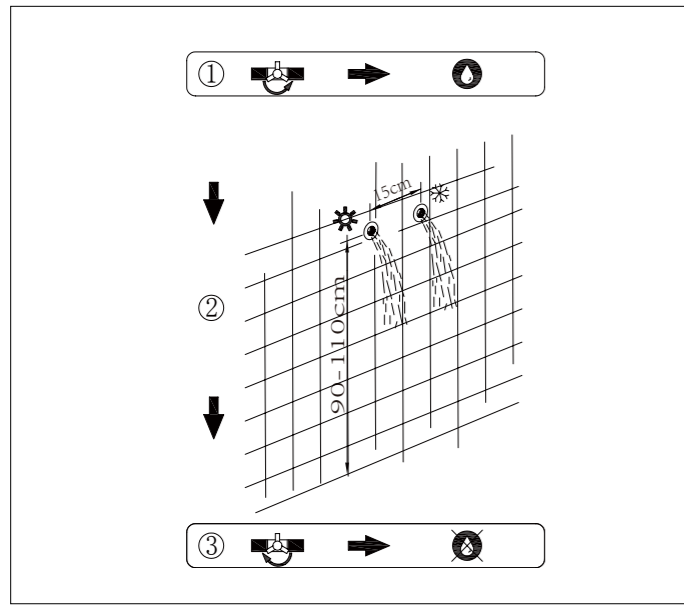

FUTUR BATH

www.futurbath.com

ASSEMBLY INSTRUCTIONS

INSTRUCCIONES DE MONTAJE / INSTRUCTIONS DE MONTAGE

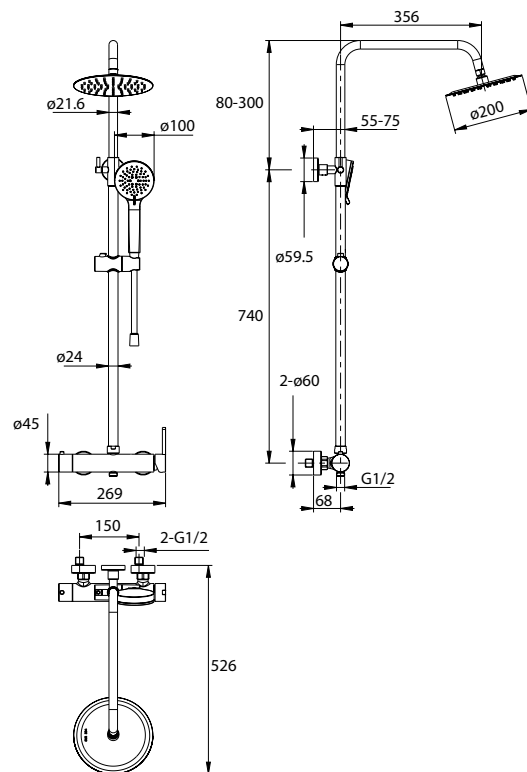



IMPORTANT NOTE_CLEANING THE FAUCETS / NOTA IMPORTANTE_ LIMPIEZA DE LA GRIFERÍA / NOTE IMPORTANTE_ NETTOYER LES ROBINETS

- Cleaning products may lead to further damage of certain surfaces.
- Do not mix cleaning products under no circumstances as they may give off harmful gases.
- Do not use rough cloths, abrasive cleaners, bleachers or whiteners with chlorine.
- Use only specific cleaners or the ones advised by the manufacturer for each surface and finishes.

·Los productos de limpieza pueden empeorar el deterioro de ciertas superficies.
·Se aconseja que no mezcle en ningún caso productos de limpieza ya que pueden emitir gases tóxicos.
·No emplee en la limpieza tejidos rugosos, limpiadores abrasivos ni lejías o blanqueadores con cloro.
·Utilice únicamente limpiadores específicos o aconsejados por el fabricante para cada superficie y acabado.

·Les produits de nettoyage peuvent endommager certaines surfaces.
·Jamais mélanger les produits de nettoyage car ils peuvent dégager des gaz nocifs.
·N'utilisez pas de chiffons rugueux, de nettoyeurs abrasifs, lessive ou blanchisseurs avec du chlore.
·N'utilisez que des nettoyeurs spécifiques ou ceux recommandés par le fabricant pour chaque surface et chaque finition.

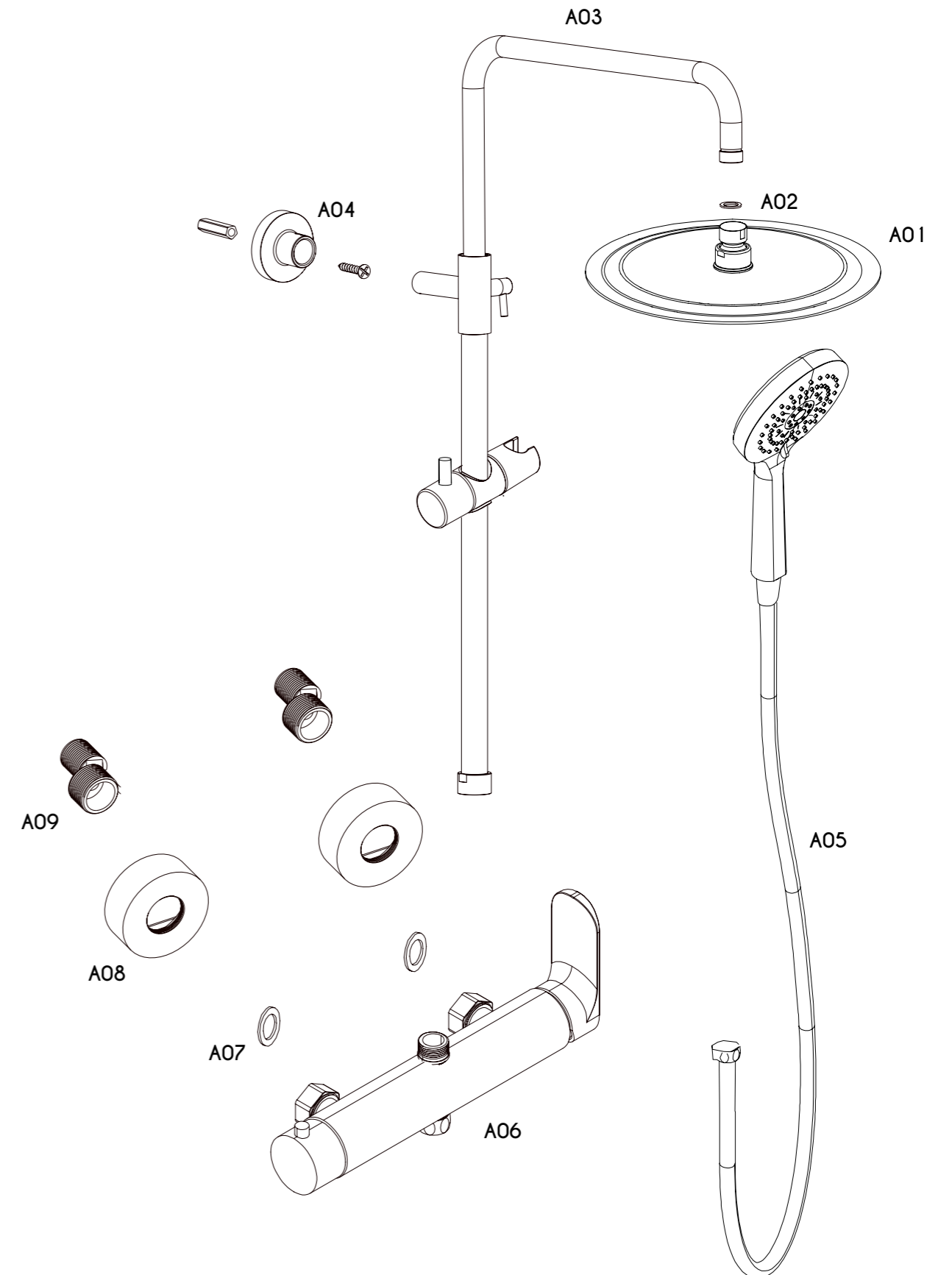

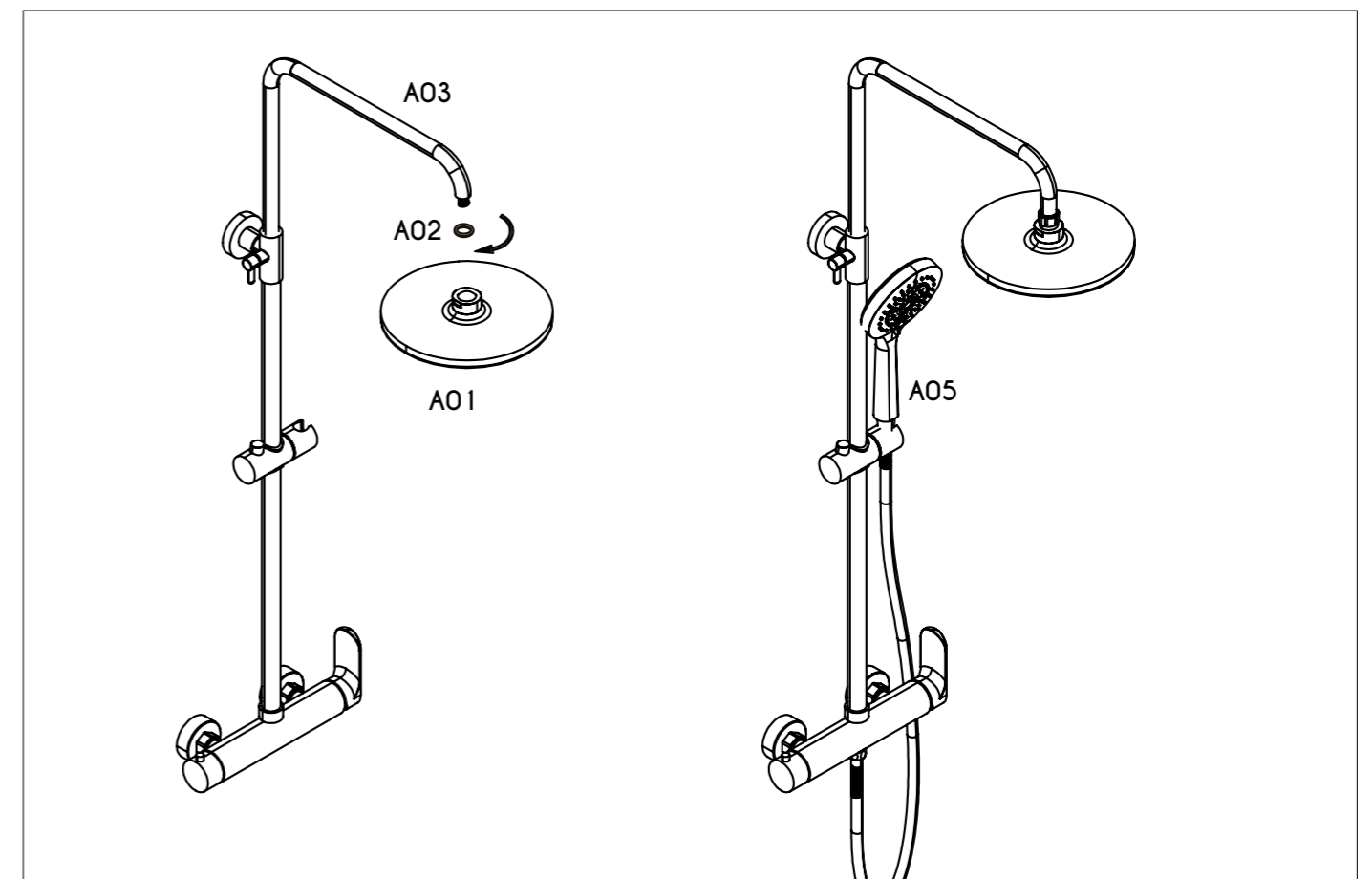
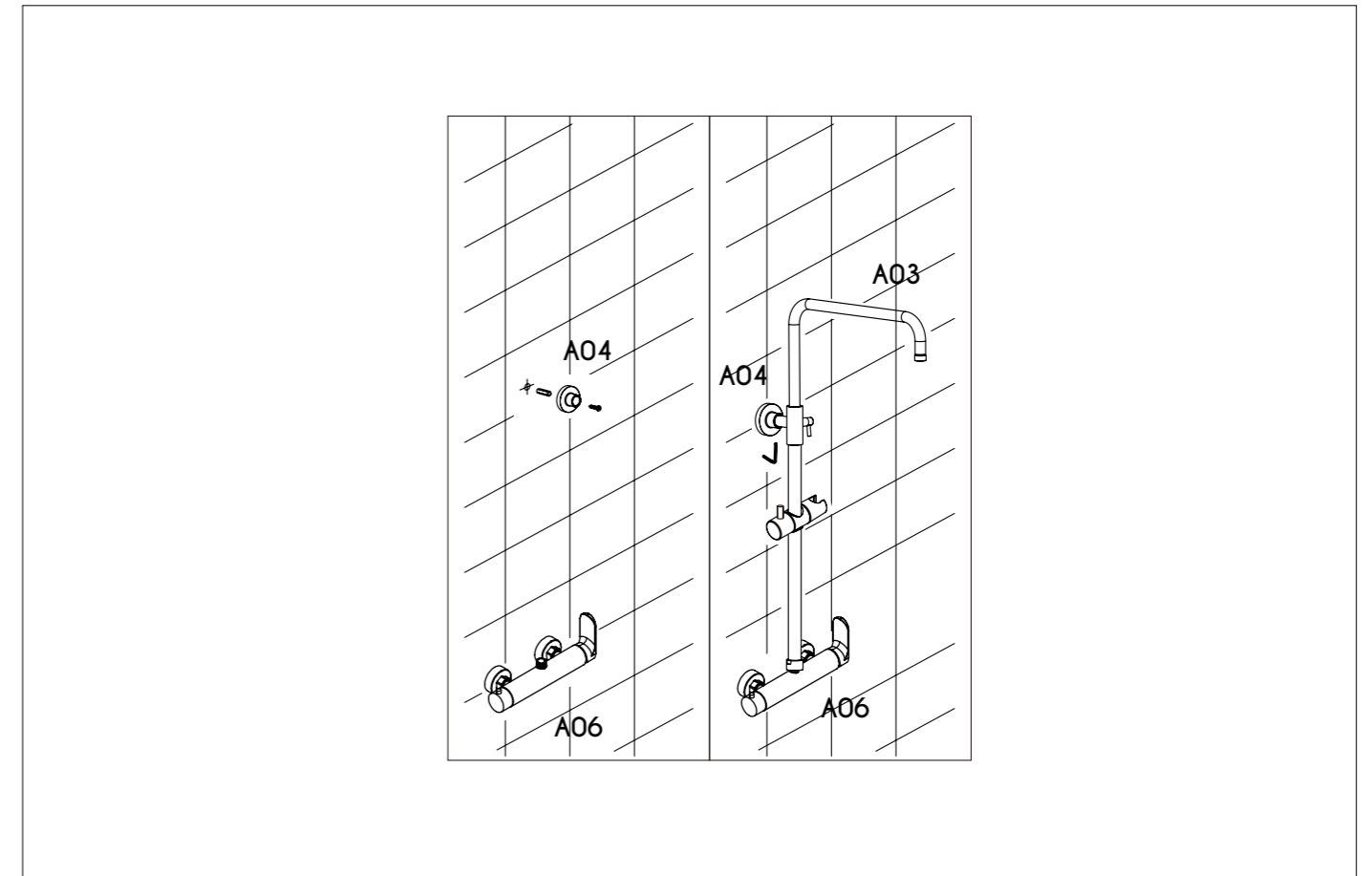
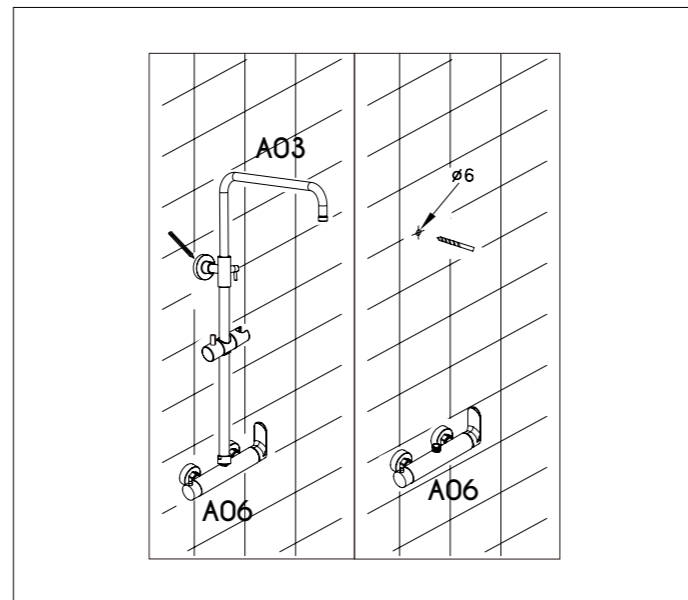
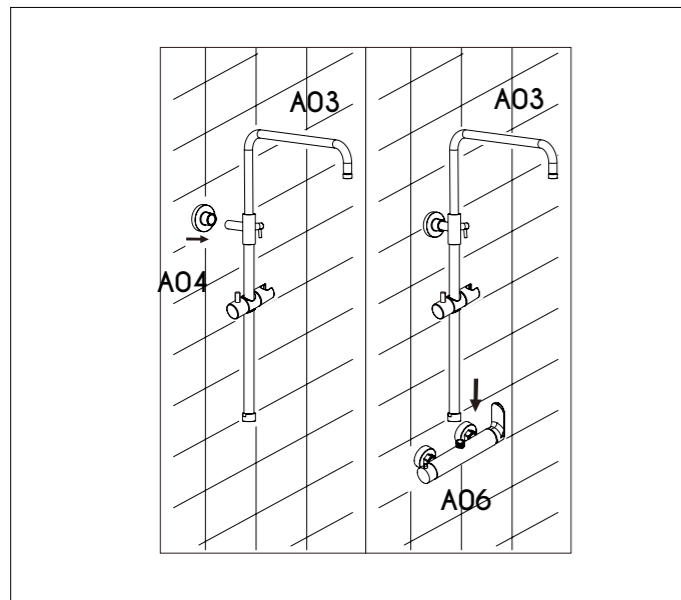
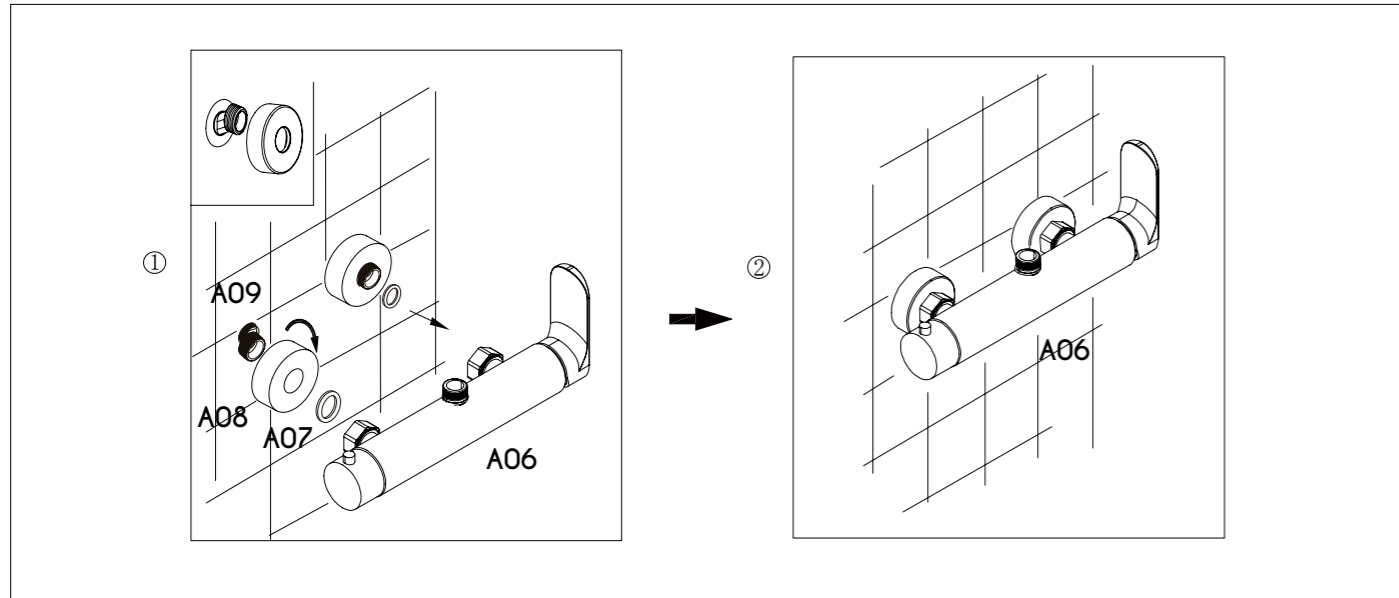
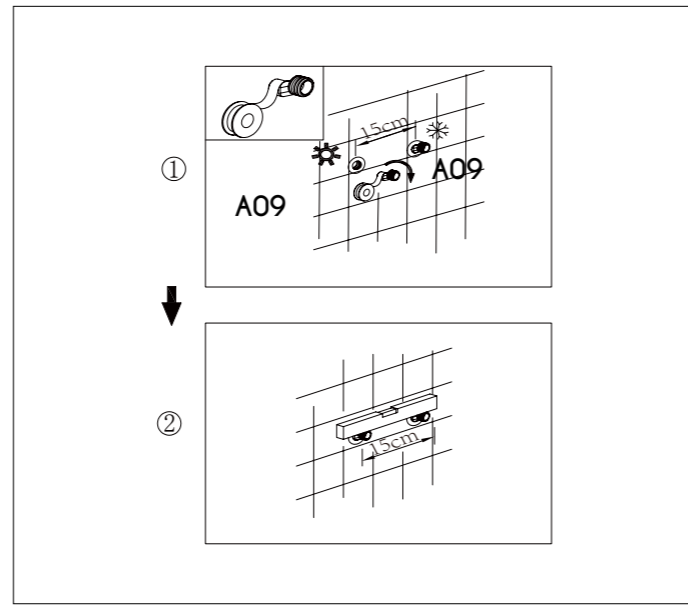
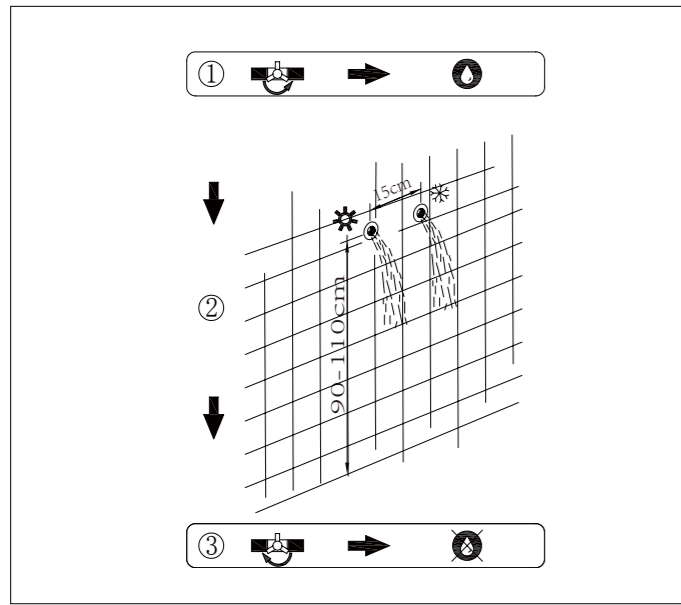

FUTUR BATH

www.futurbath.com

ASSEMBLY INSTRUCTIONS

INSTRUCCIONES DE MONTAJE / INSTRUCTIONS DE MONTAGE

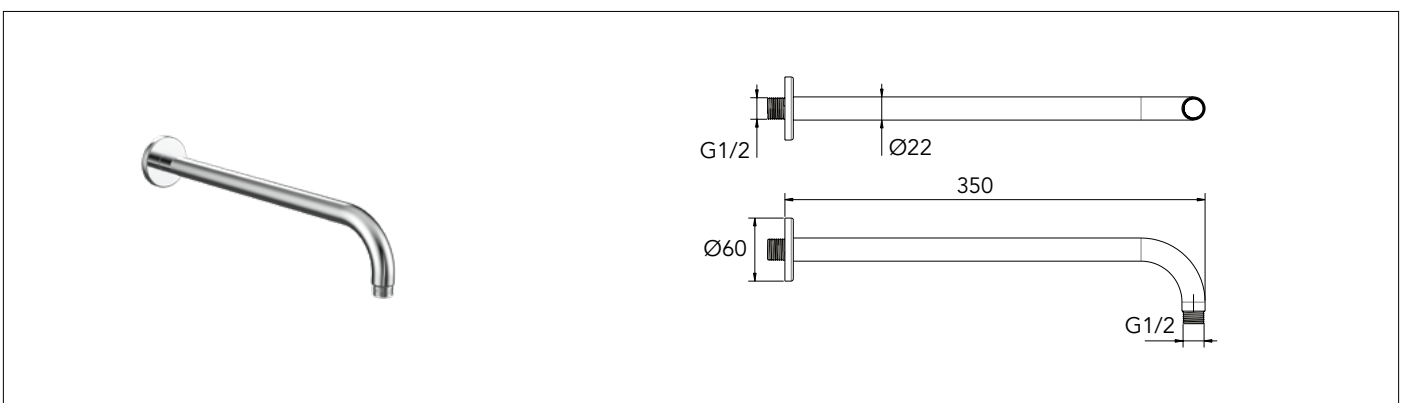
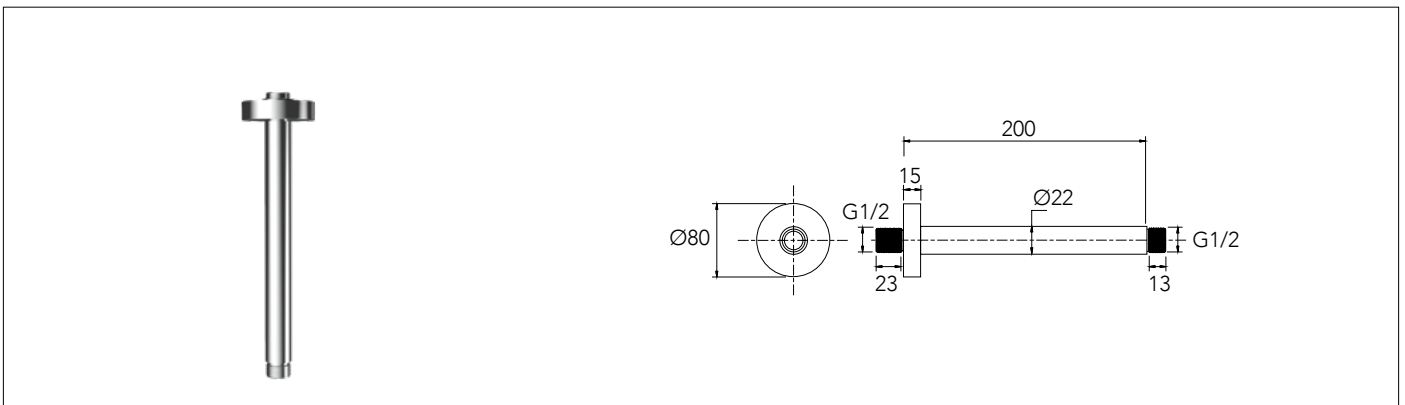
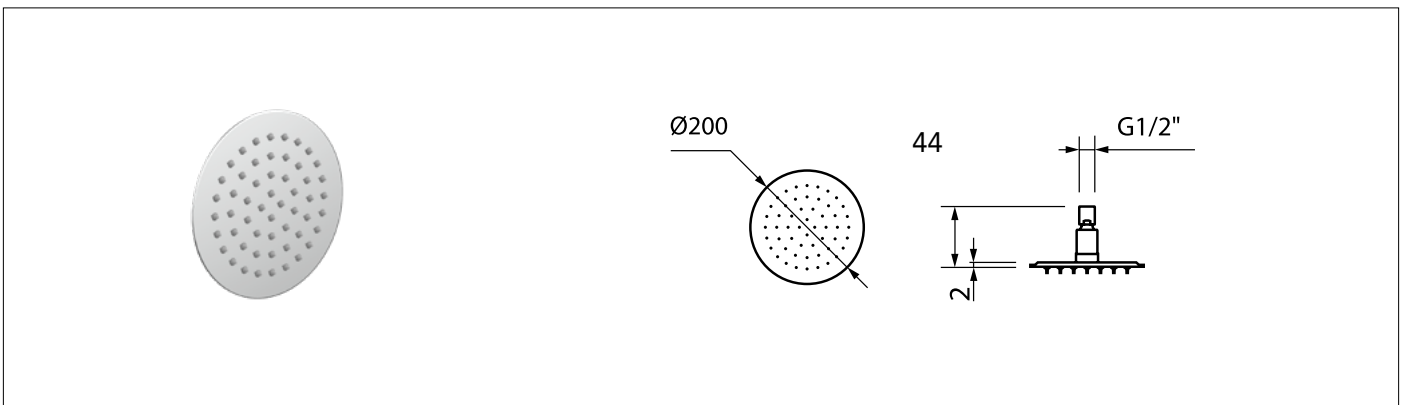
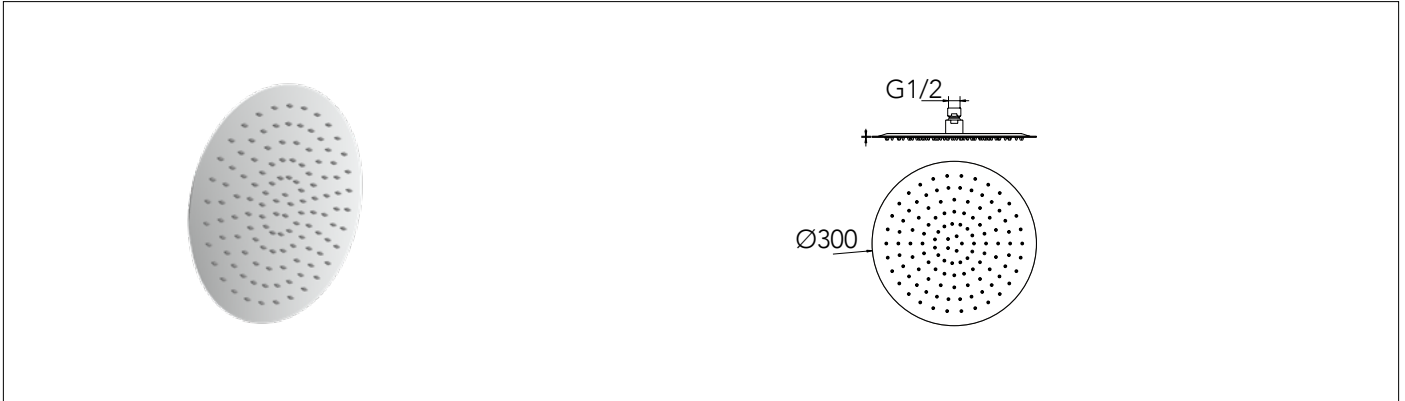



IMPORTANT NOTE_CLEANING THE FAUCETS / NOTA IMPORTANTE_ LIMPIEZA DE LA GRIFERÍA / NOTE IMPORTANTE_ NETTOYER LES ROBINETS

- Cleaning products may lead to further damage of certain surfaces.
- Do not mix cleaning products under no circumstances as they may give off harmful gases.
- Do not use rough cloths, abrasive cleaners, bleachers or whiteners with chlorine.
- Use only specific cleaners or the ones advised by the manufacturer for each surface and finishes.

·Los productos de limpieza pueden empeorar el deterioro de ciertas superficies.
·Se aconseja que no mezcle en ningún caso productos de limpieza ya que pueden emitir gases tóxicos.
·No emplee en la limpieza tejidos rugosos, limpiadores abrasivos ni lejías o blanqueadores con cloro.
·Utilice únicamente limpiadores específicos o aconsejados por el fabricante para cada superficie y acabado.

·Les produits de nettoyage peuvent endommager certaines surfaces.
·Jamais mélanger les produits de nettoyage car ils peuvent dégager des gaz nocifs.
·N'utilisez pas de chiffons rugueux, de nettoyeurs abrasifs, lessive ou blanchisseurs avec du chlore.
·N'utilisez que des nettoyeurs spécifiques ou ceux recommandés par le fabricant pour chaque surface et chaque finition.

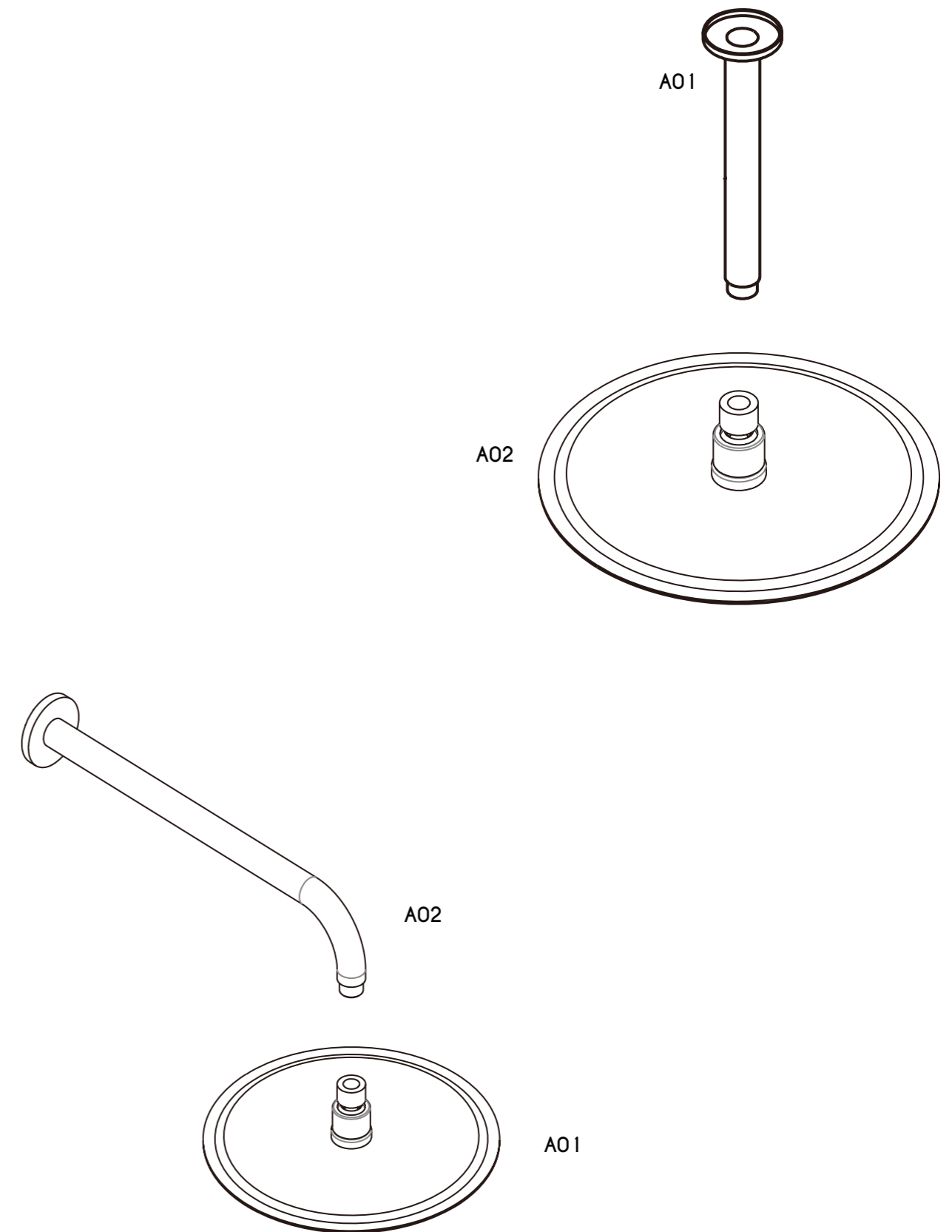

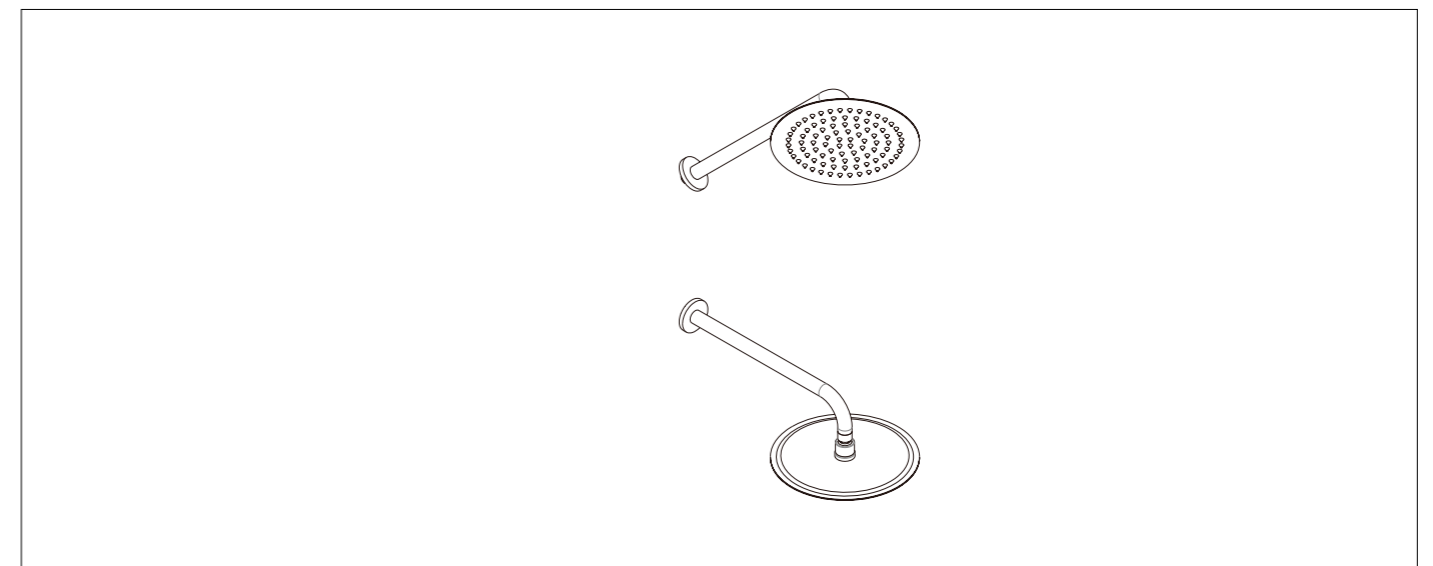
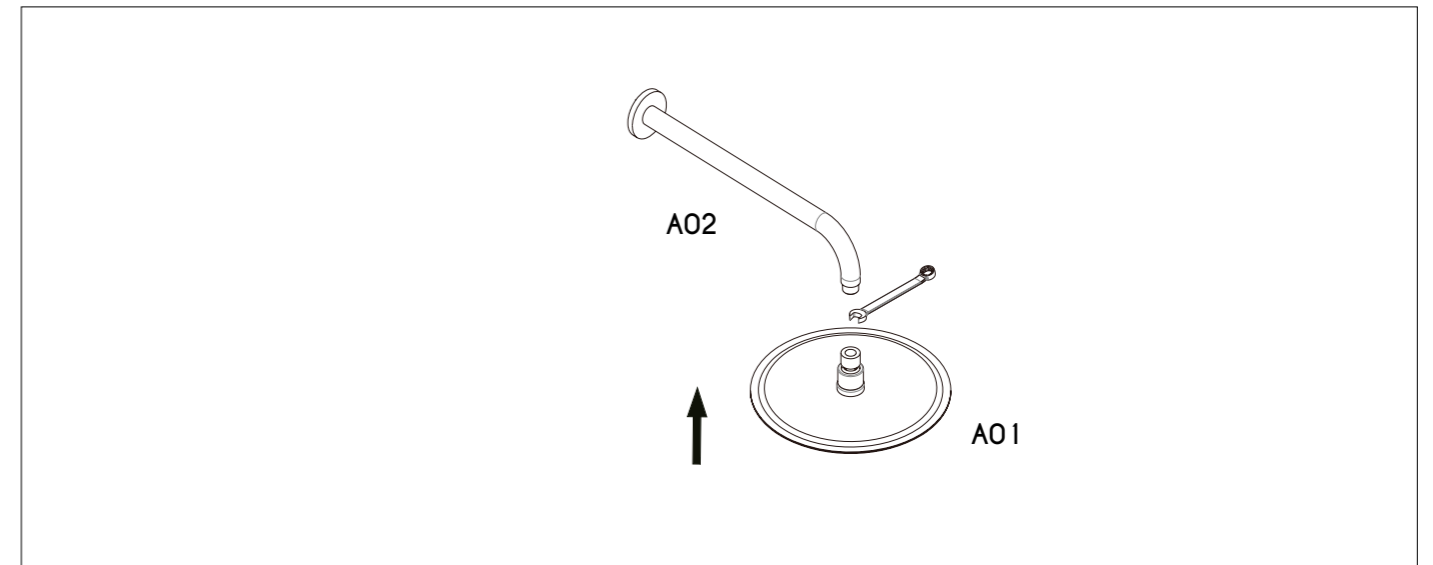
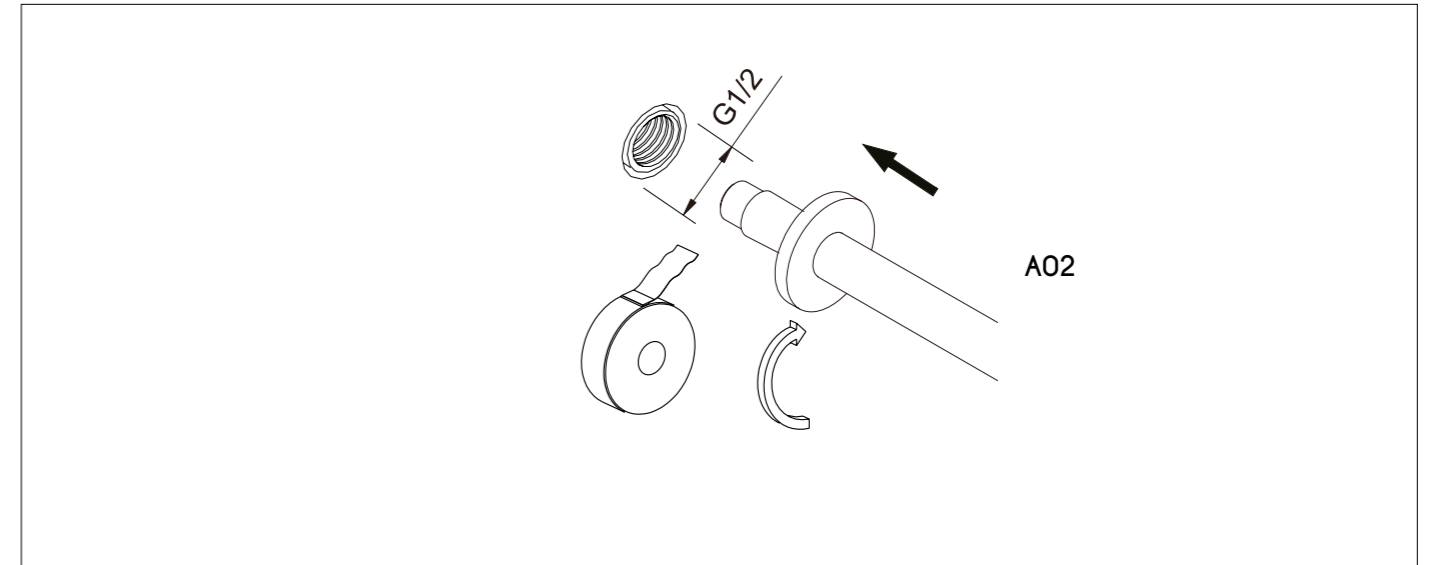
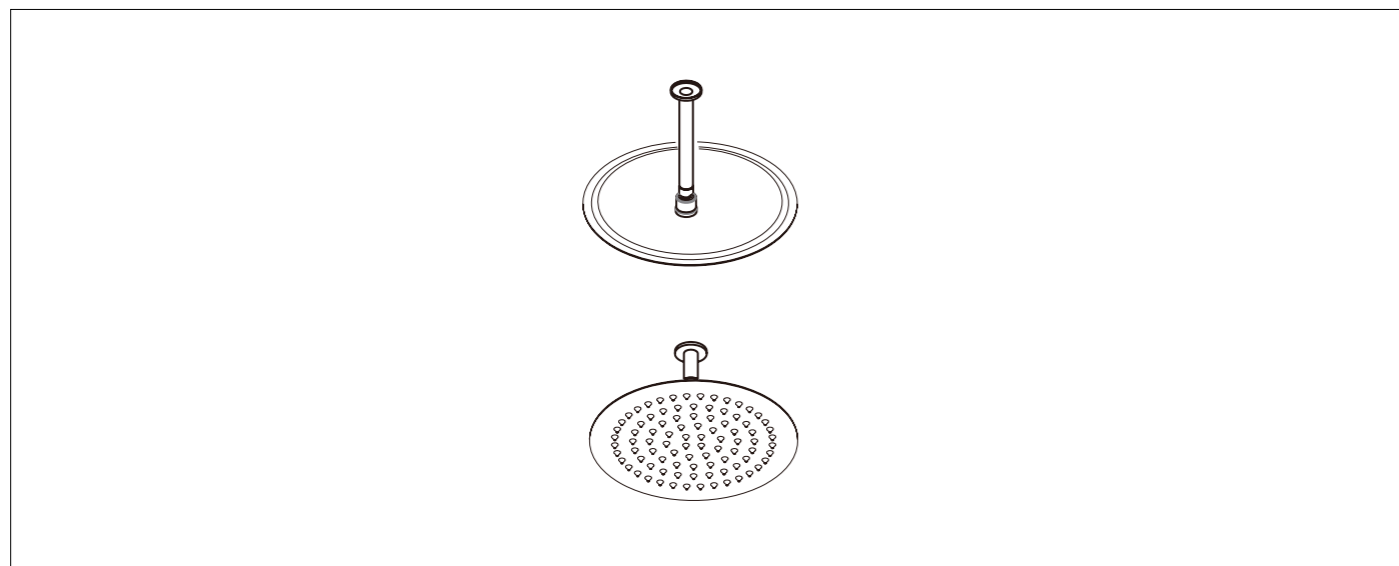
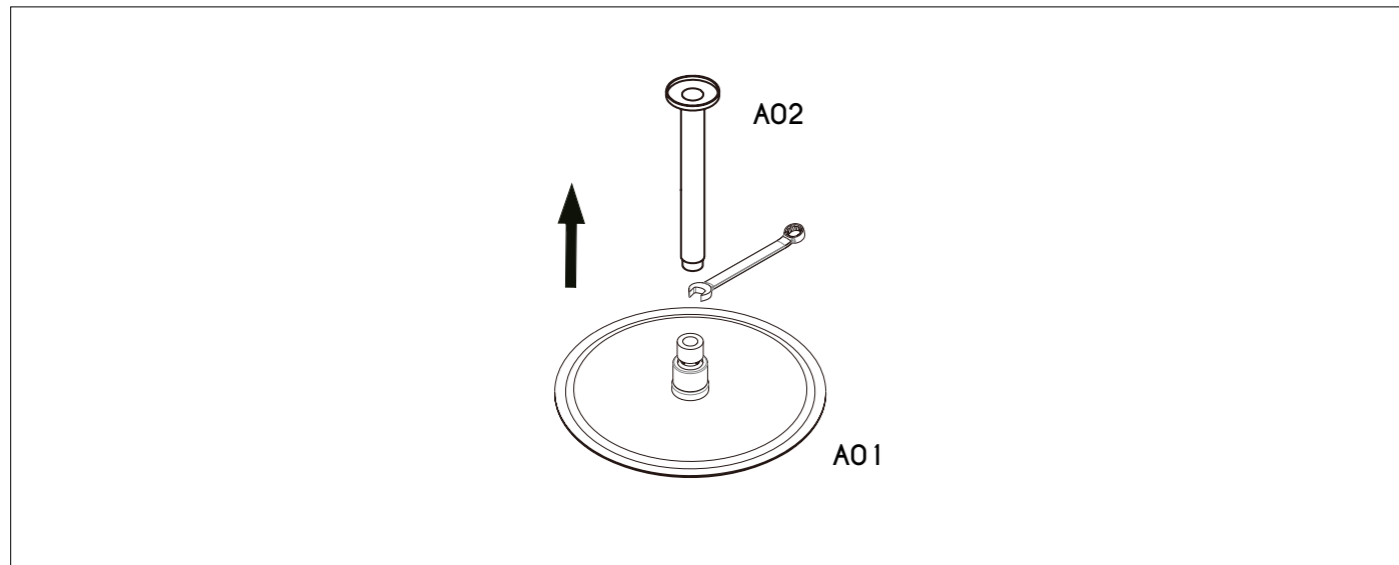
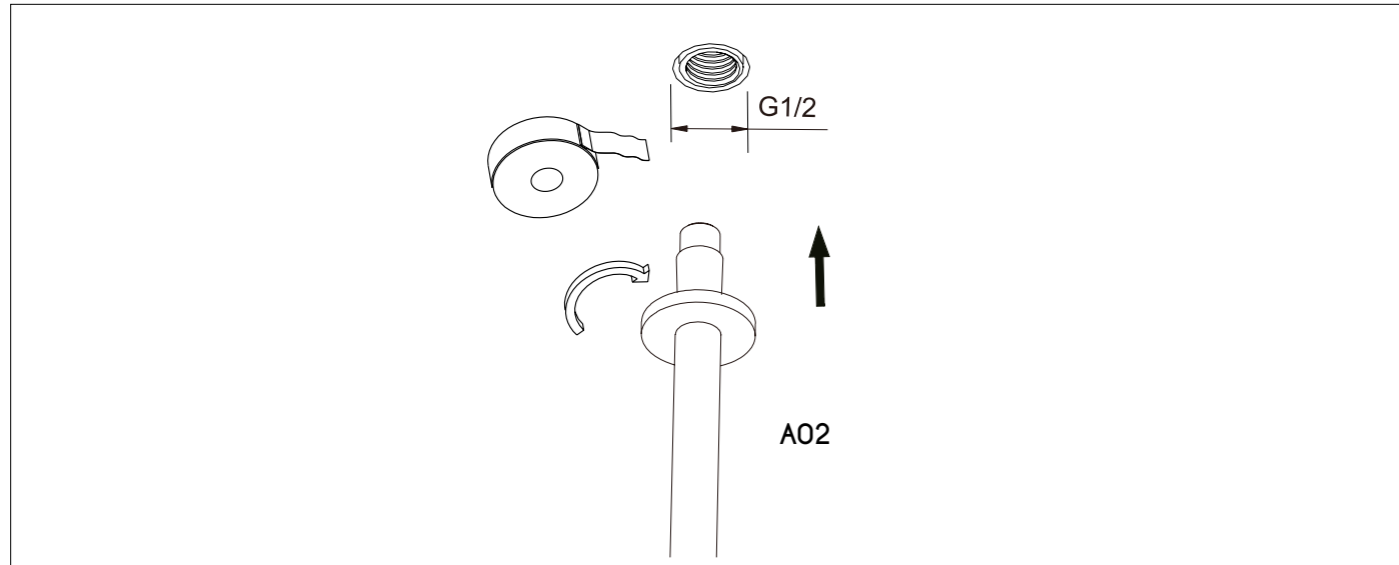

FUTUR BATH

www.futurbath.com

FLOW PRO

MONOMANDO EXTERNO DE DUCHA
WALL-MOUNTED EXPOSED SHOWER MIXER /
MITIGEUR DOUCHE EXPOSÉ

FUTUR BATH

ASSEMBLY INSTRUCTIONS

INSTRUCCIONES DE MONTAJE / INSTRUCTIONS DE MONTAGE

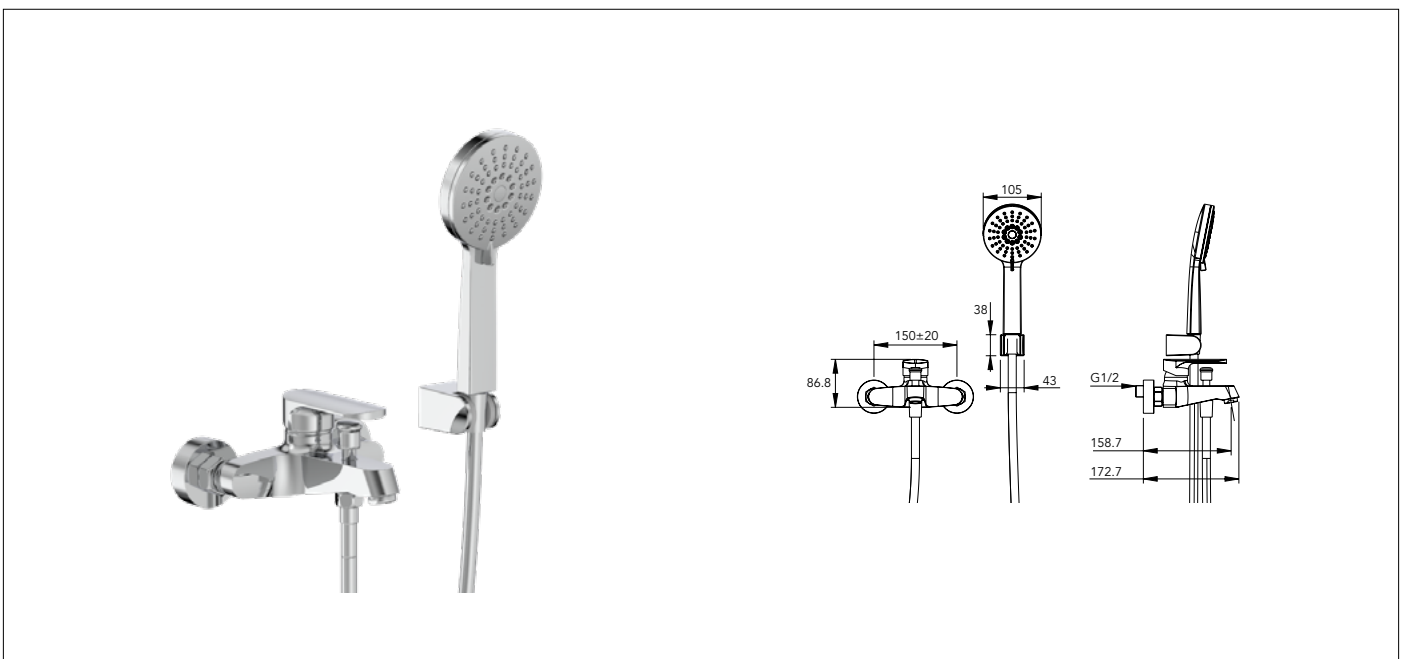
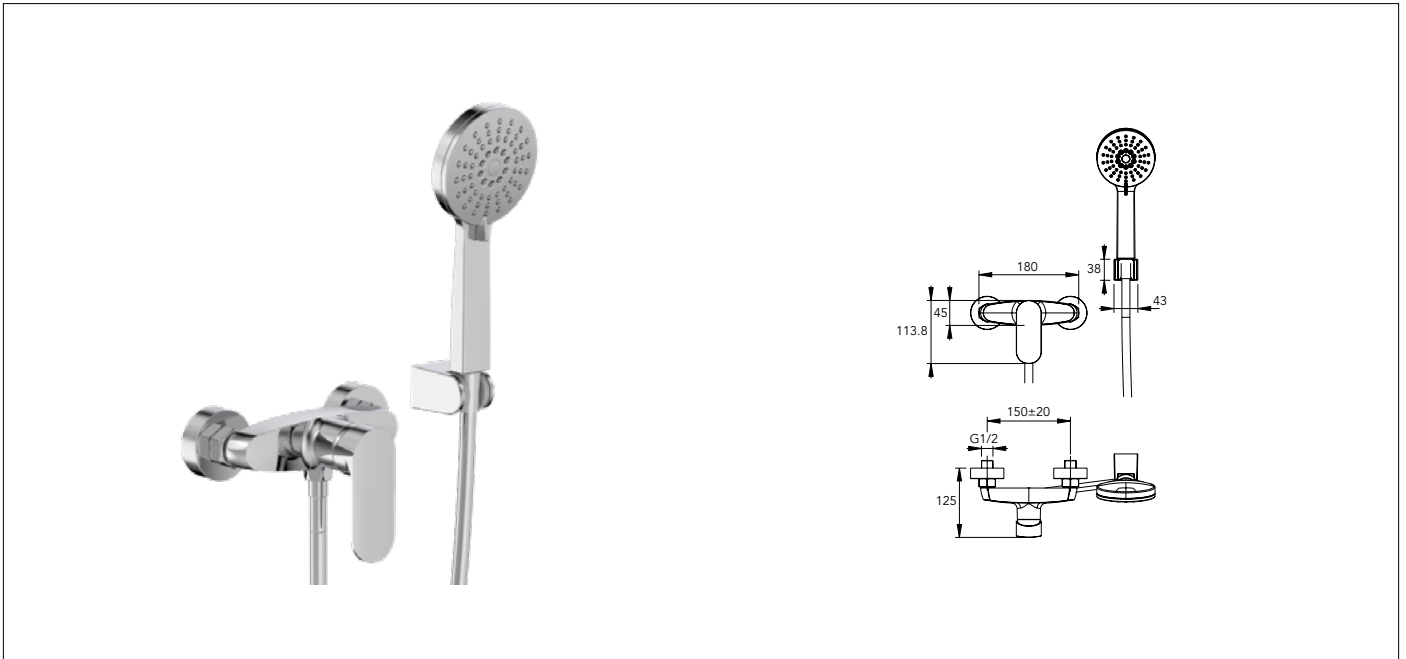



IMPORTANT NOTE_CLEANING THE FAUCETS / NOTA IMPORTANTE_ LIMPIEZA DE LA GRIFERÍA / NOTE IMPORTANTE_ NETTOYER LES ROBINETS

- Cleaning products may lead to further damage of certain surfaces.
- Do not mix cleaning products under no circumstances as they may give off harmful gases.
- Do not use rough cloths, abrasive cleaners, bleachers or whiteners with chlorine.
- Use only specific cleaners or the ones advised by the manufacturer for each surface and finishes.

·Los productos de limpieza pueden empeorar el deterioro de ciertas superficies.
·Se aconseja que no mezcle en ningún caso productos de limpieza ya que pueden emitir gases tóxicos.
·No emplee en la limpieza tejidos rugosos, limpiadores abrasivos ni lejías o blanqueadores con cloro.
·Utilice únicamente limpiadores específicos o aconsejados por el fabricante para cada superficie y acabado.

·Les produits de nettoyage peuvent endommager certaines surfaces.
·Jamais mélanger les produits de nettoyage car ils peuvent dégager des gaz nocifs.
·N'utilisez pas de chiffons rugueux, de nettoyeurs abrasifs, lessive ou blanchisseurs avec du chlore.
·N'utilisez que des nettoyeurs spécifiques ou ceux recommandés par le fabricant pour chaque surface et chaque finition.

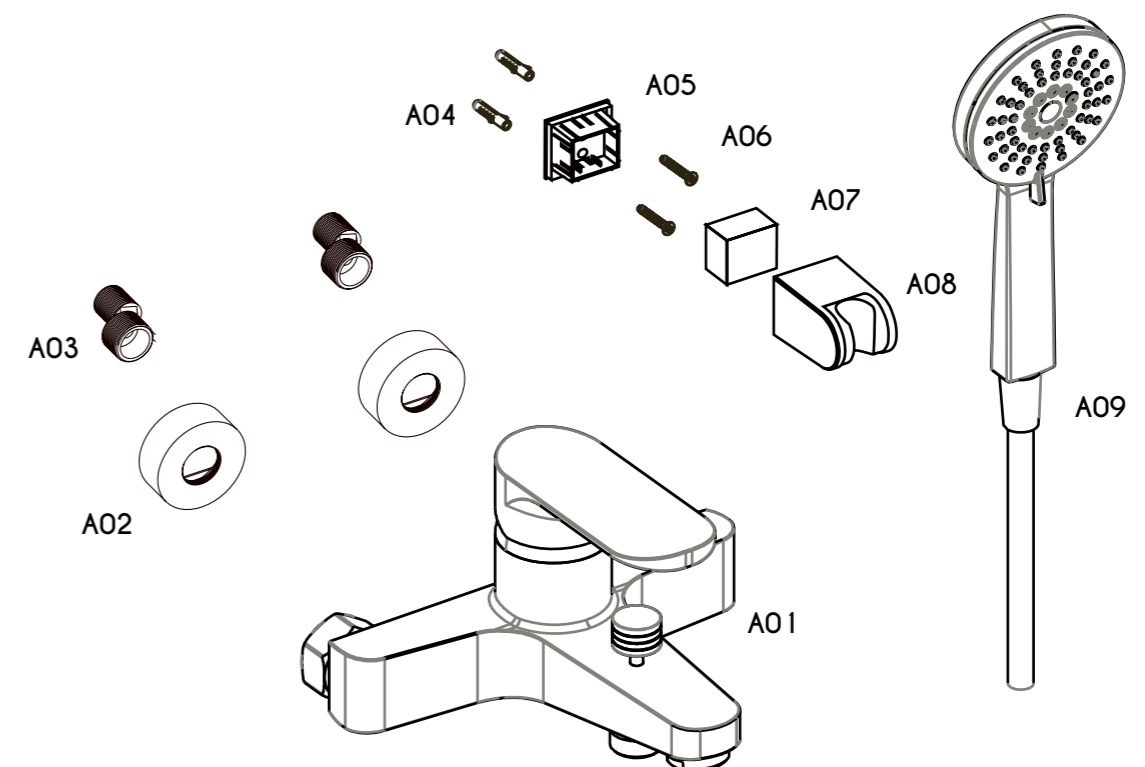
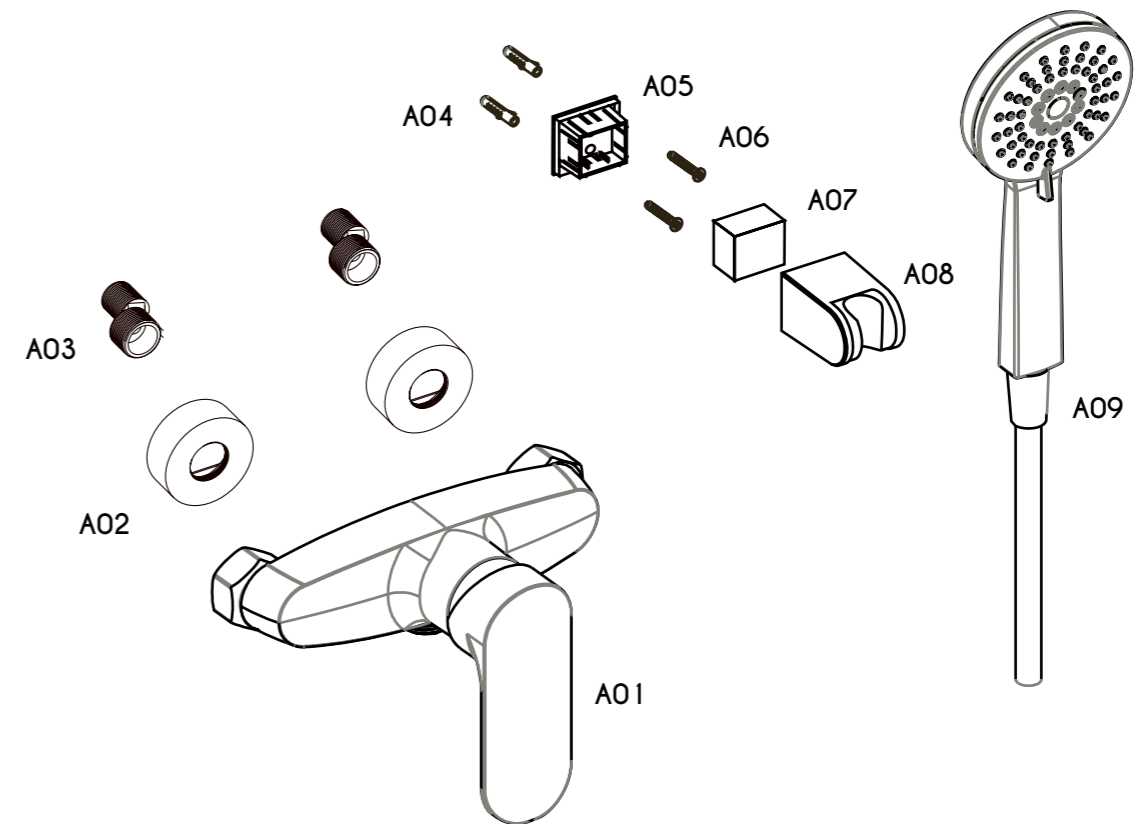

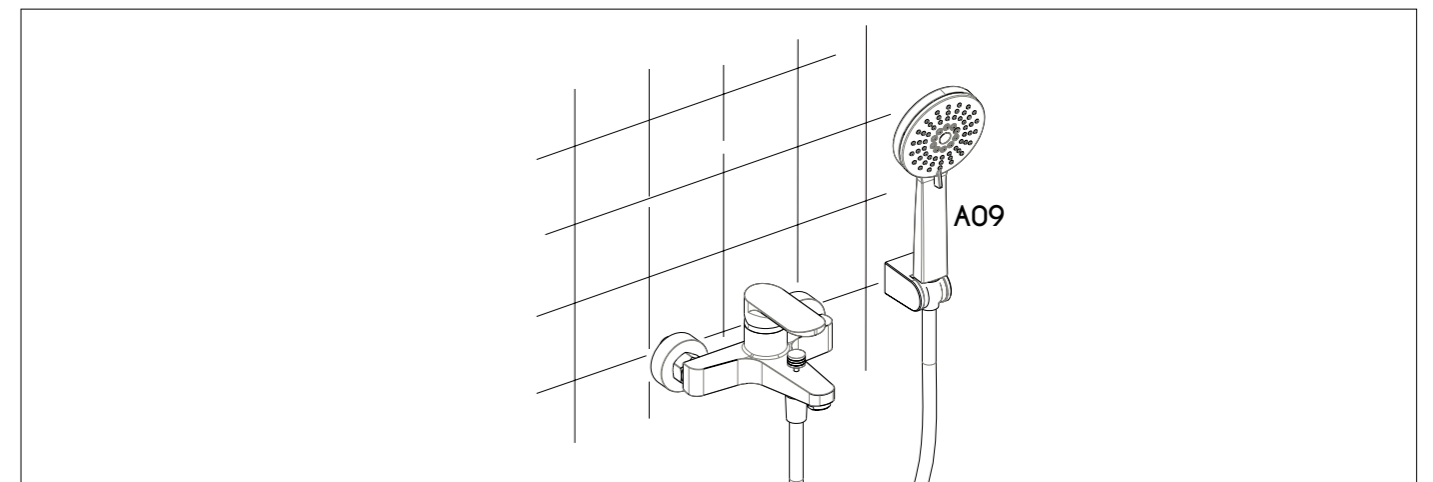
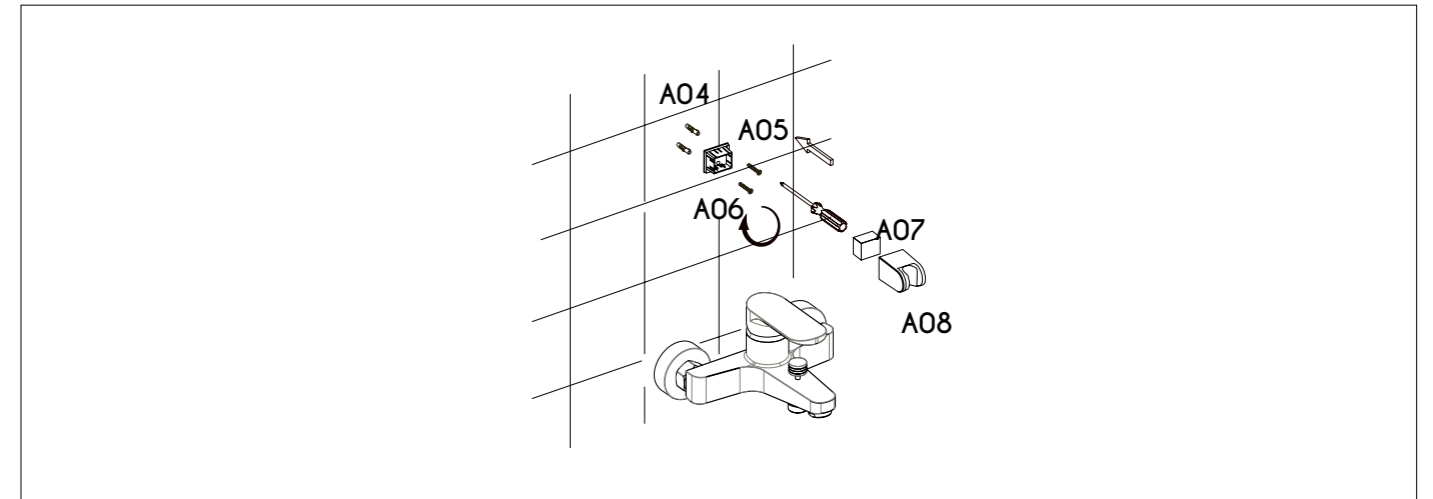
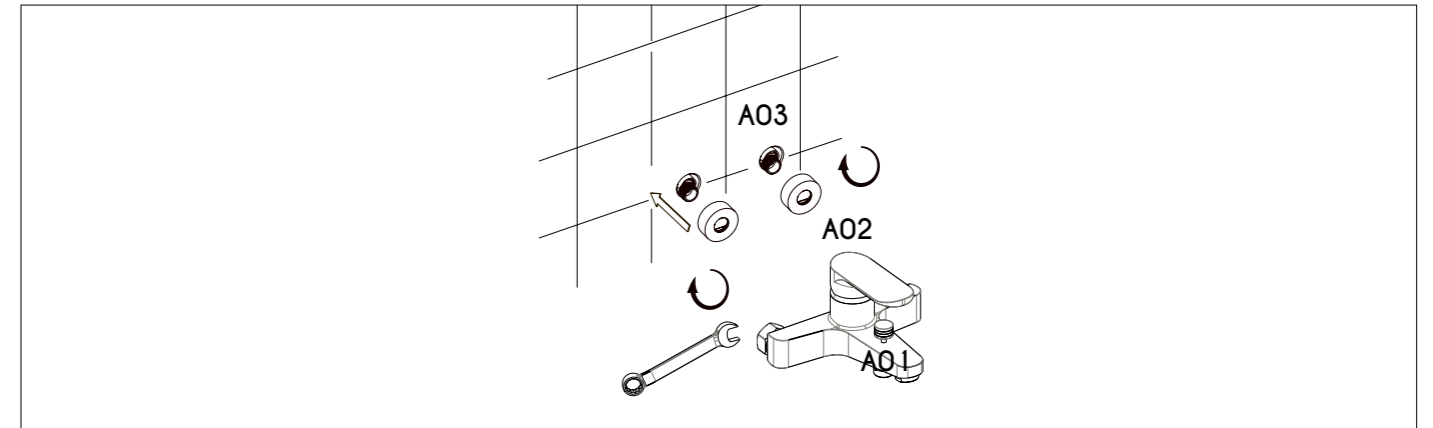
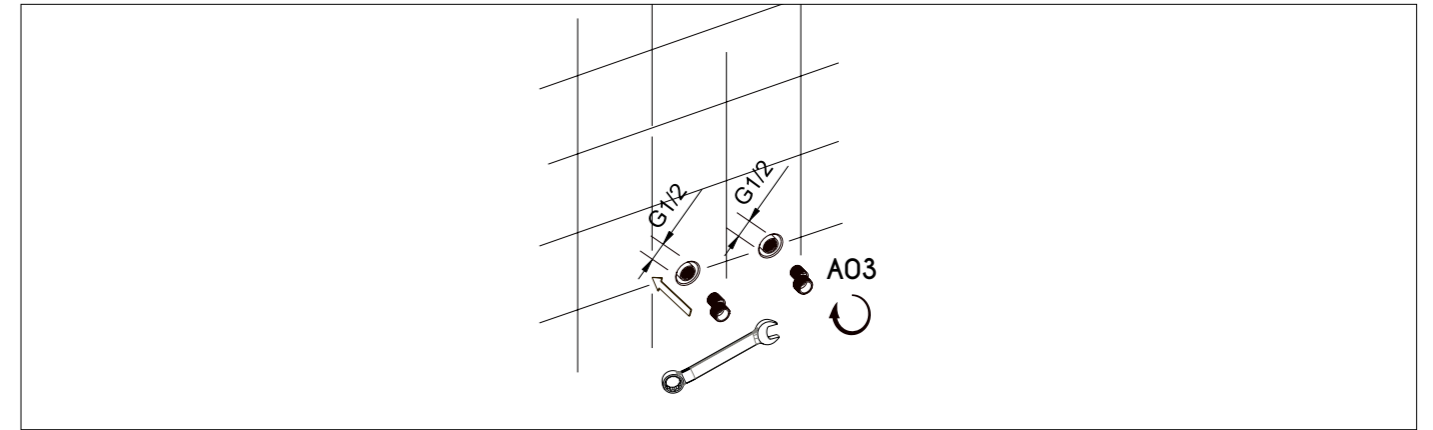
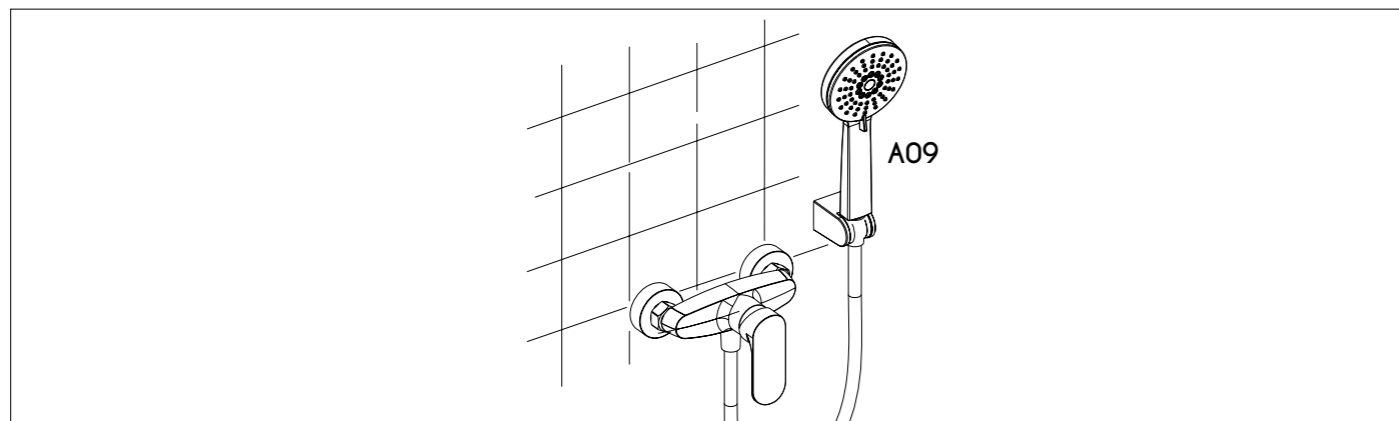
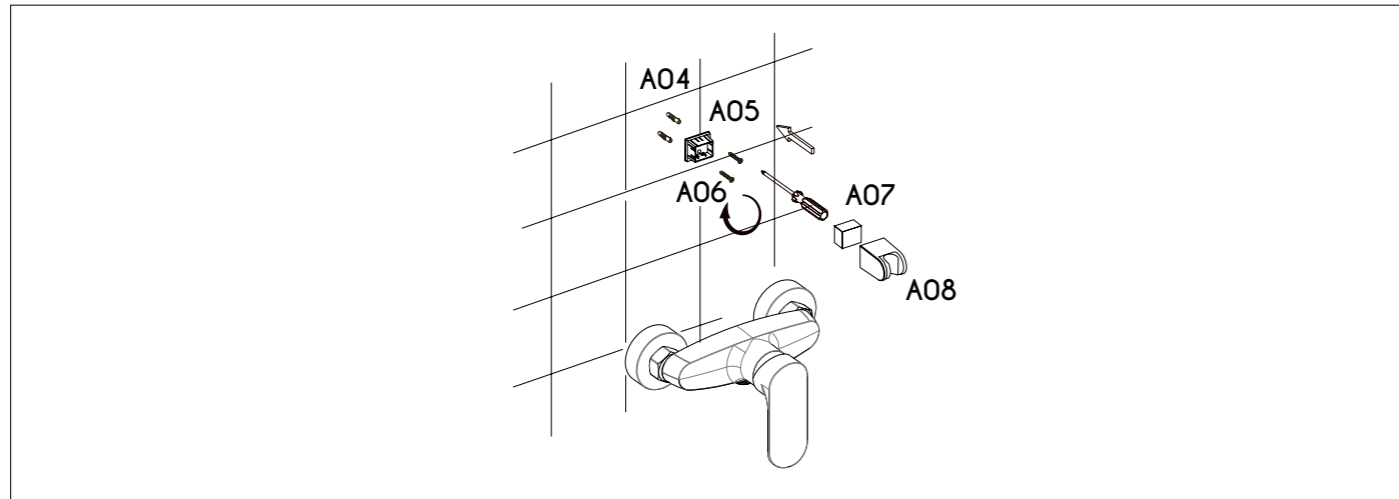
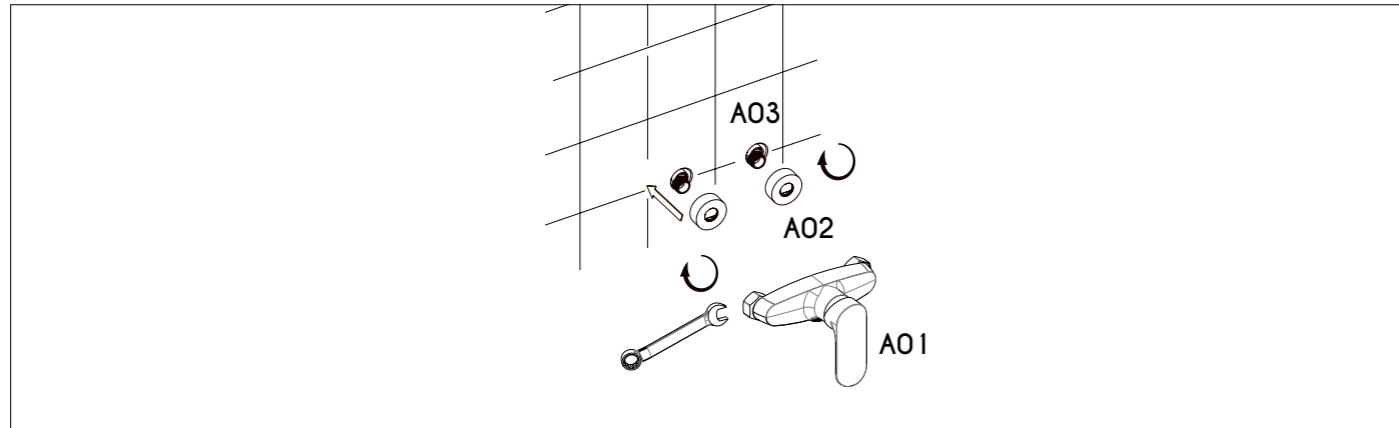
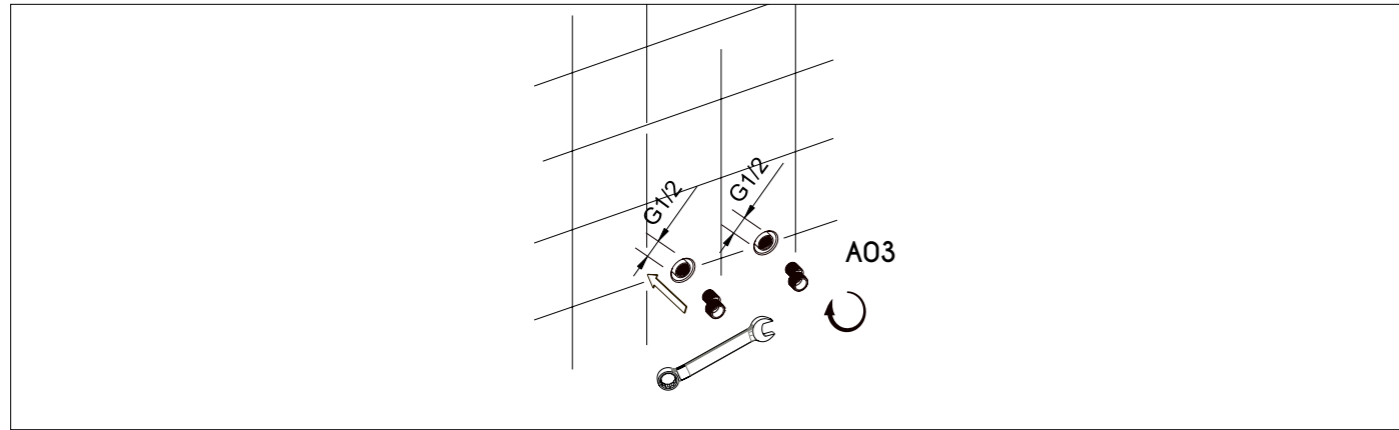

FUTUR BATH

www.futurbath.com

ASSEMBLY INSTRUCTIONS

INSTRUCCIONES DE MONTAJE / INSTRUCTIONS DE MONTAGE

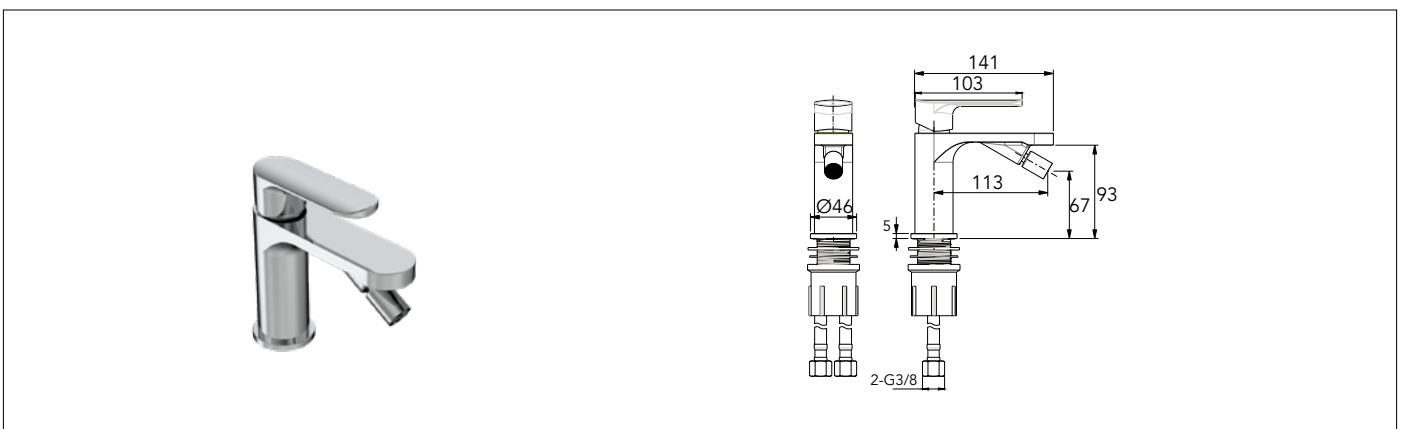
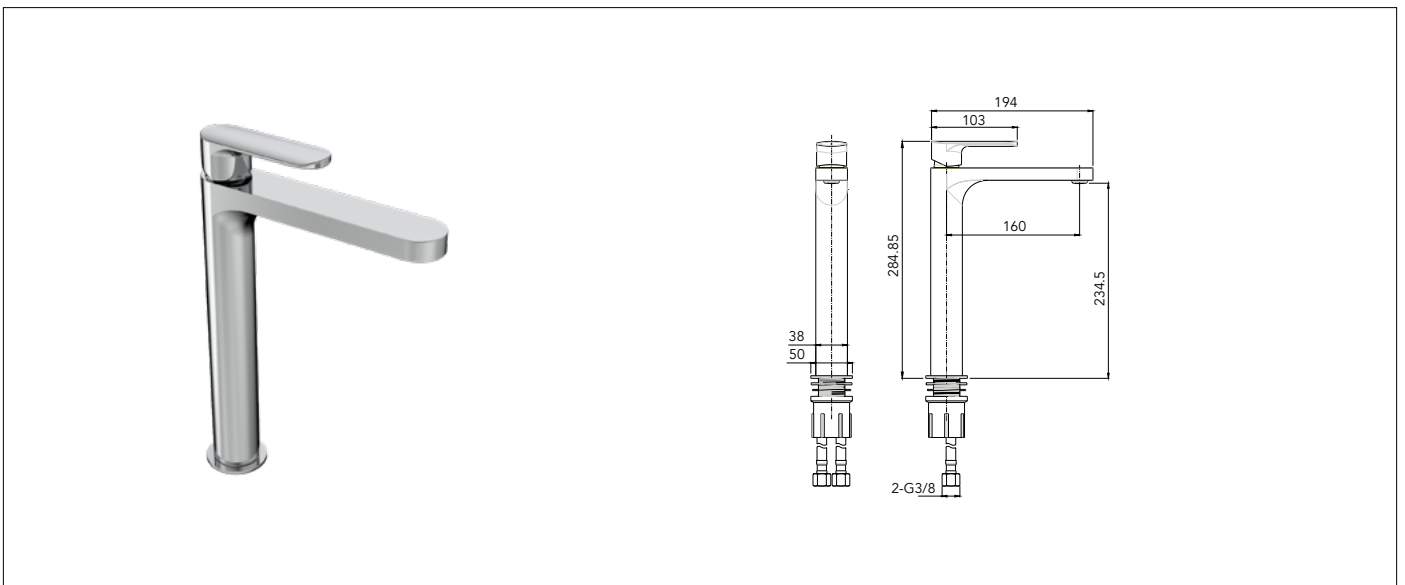
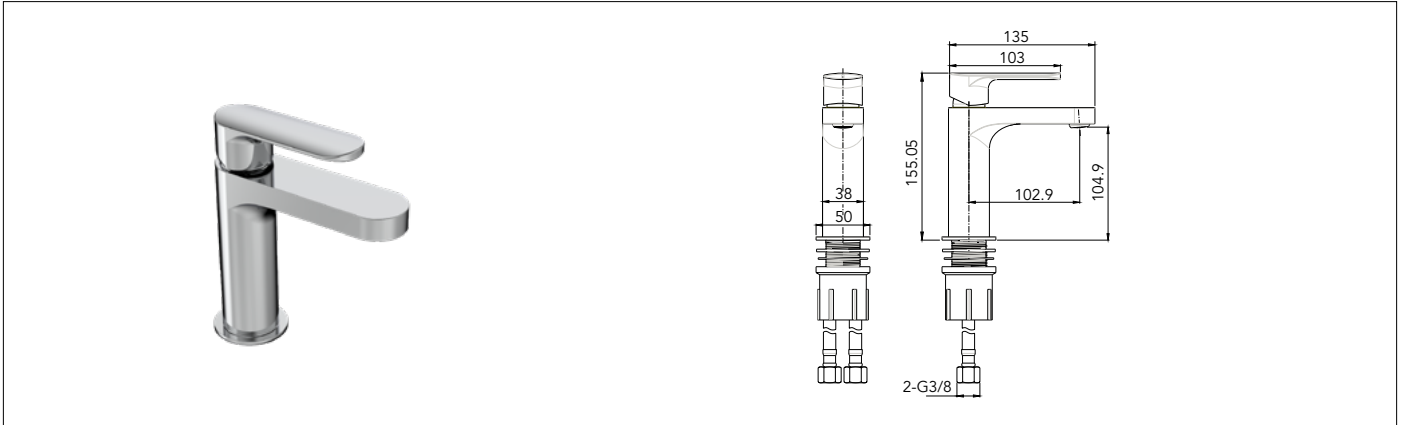



IMPORTANT NOTE_CLEANING THE FAUCETS / NOTA IMPORTANTE_ LIMPIEZA DE LA GRIFERÍA / NOTE IMPORTANTE_ NETTOYER LES ROBINETS

- Cleaning products may lead to further damage of certain surfaces.
- Do not mix cleaning products under no circumstances as they may give off harmful gases.
- Do not use rough cloths, abrasive cleaners, bleachers or whiteners with chlorine.
- Use only specific cleaners or the ones advised by the manufacturer for each surface and finishes.

·Los productos de limpieza pueden empeorar el deterioro de ciertas superficies.
 ·Se aconseja que no mezcle en ningún caso productos de limpieza ya que pueden emitir gases tóxicos.
 ·No emplee en la limpieza tejidos rugosos, limpiadores abrasivos ni lejías o blanqueadores con cloro.
 ·Utilice únicamente limpiadores específicos o aconsejados por el fabricante para cada superficie y acabado.

·Les produits de nettoyage peuvent endommager certaines surfaces.
 ·Jamais mélanger les produits de nettoyage car ils peuvent dégager des gaz nocifs.
 ·N'utilisez pas de chiffons rugueux, de nettoyeurs abrasifs, lessive ou blanchisseurs avec du chlore.
 ·N'utilisez que des nettoyeurs spécifiques ou ceux recommandés par le fabricant pour chaque surface et chaque finition.

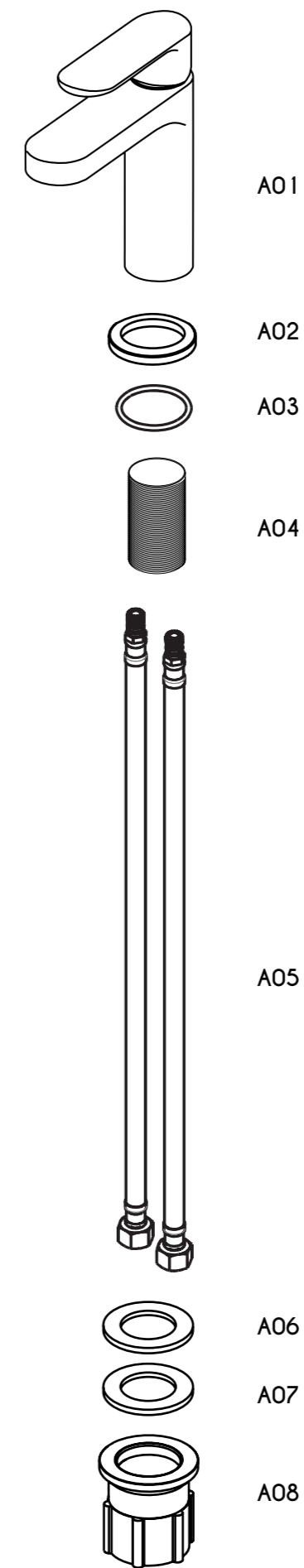

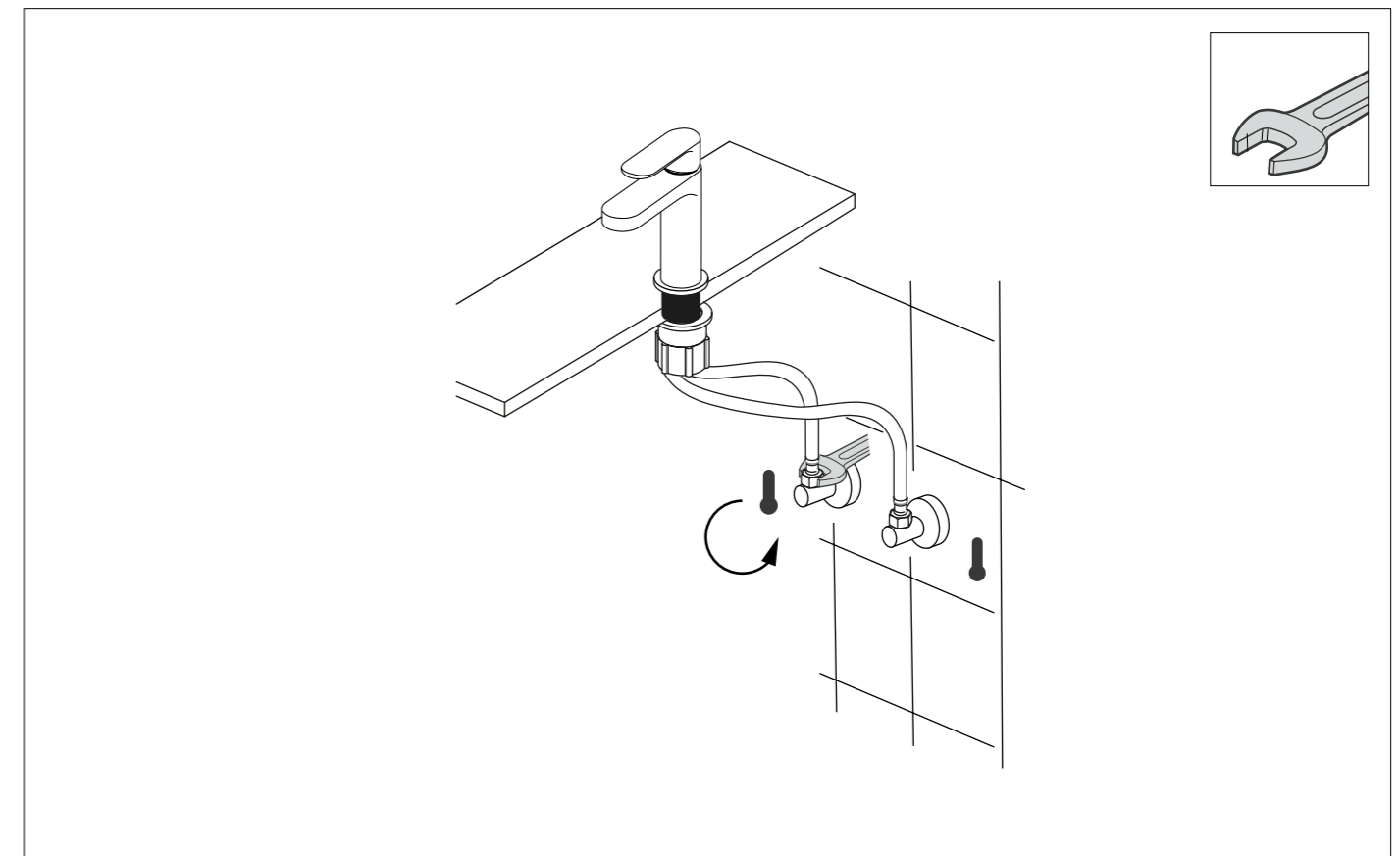
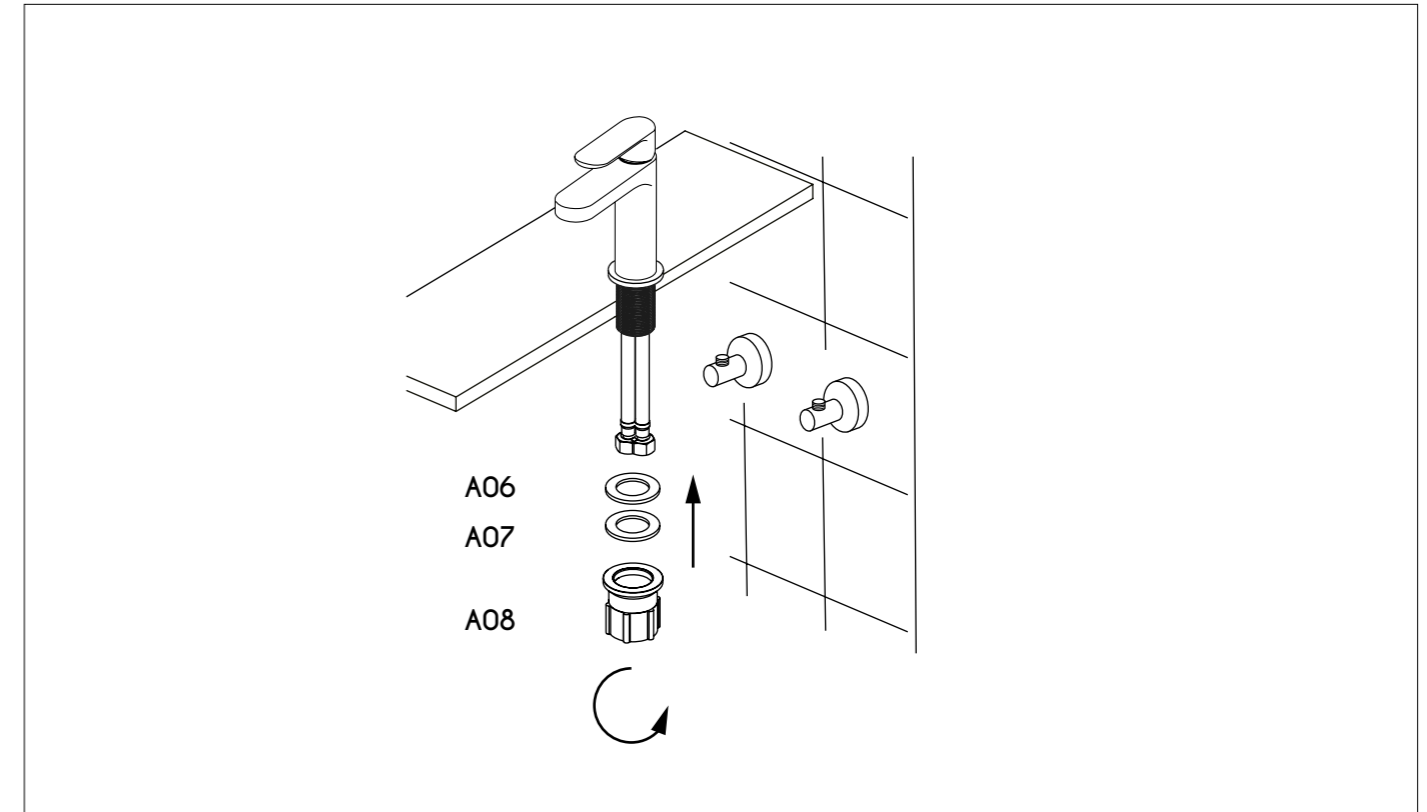
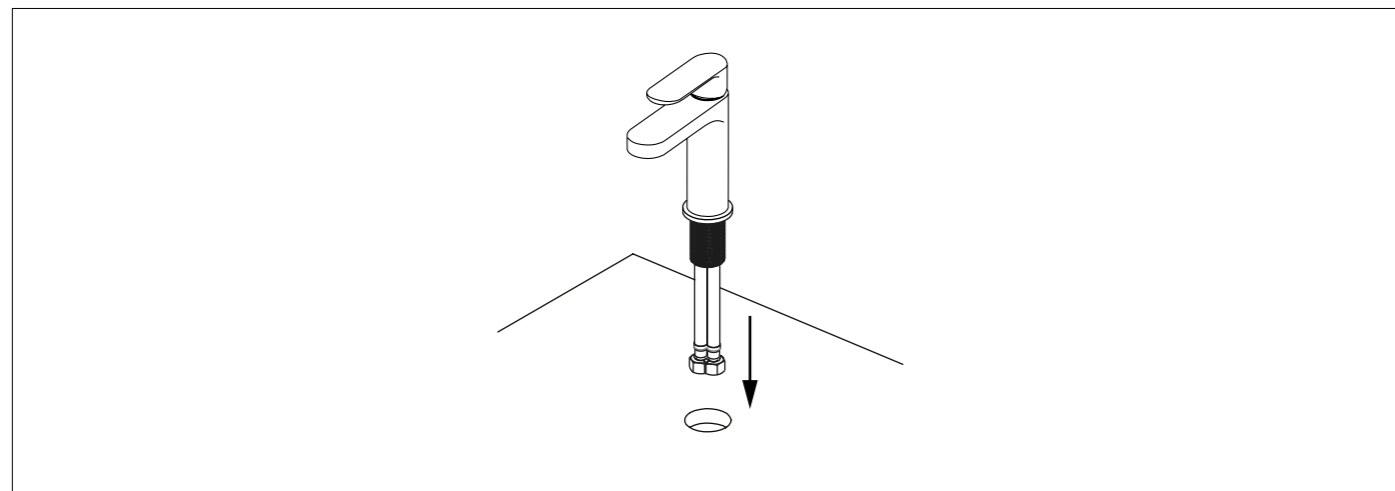
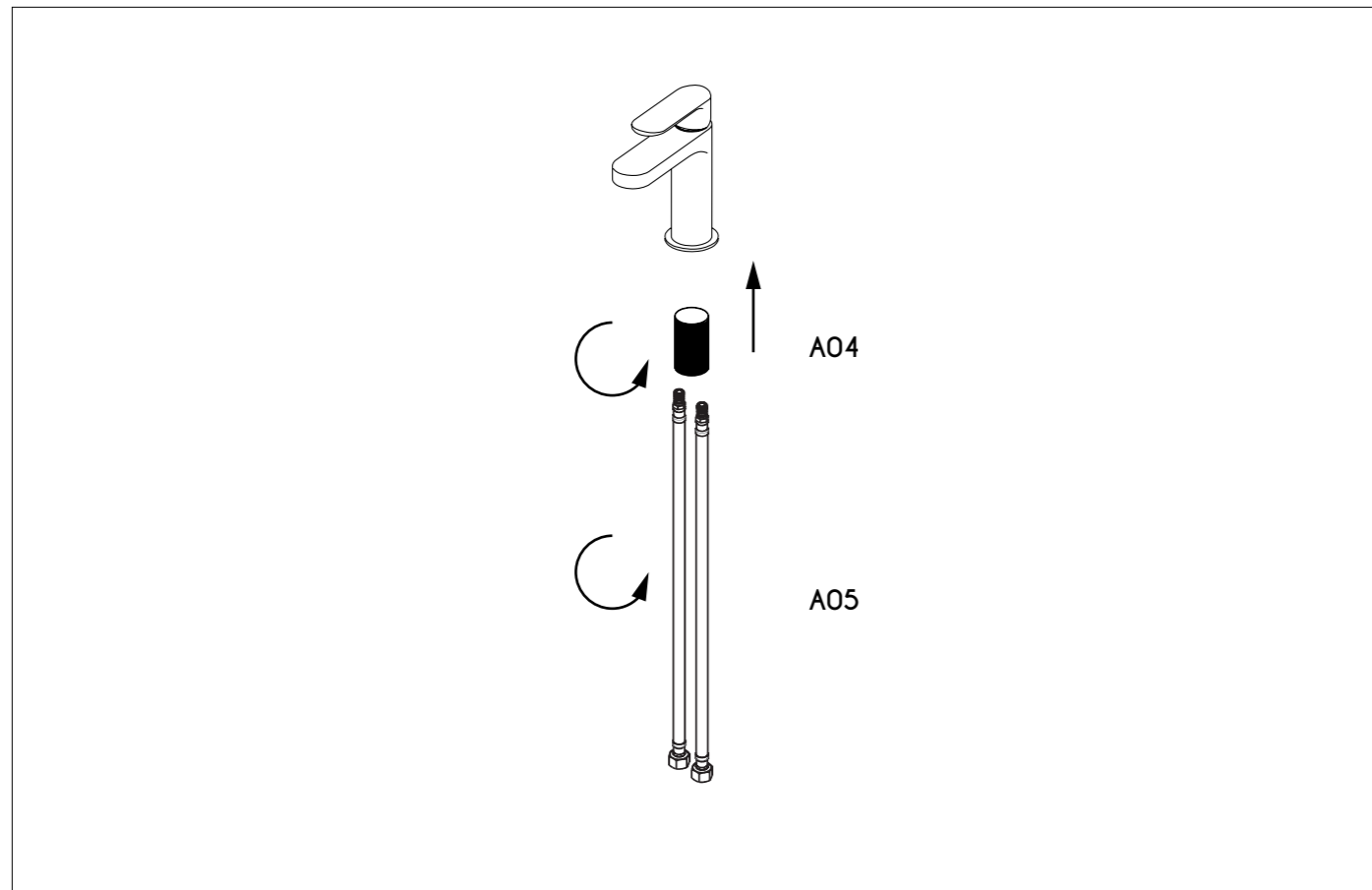
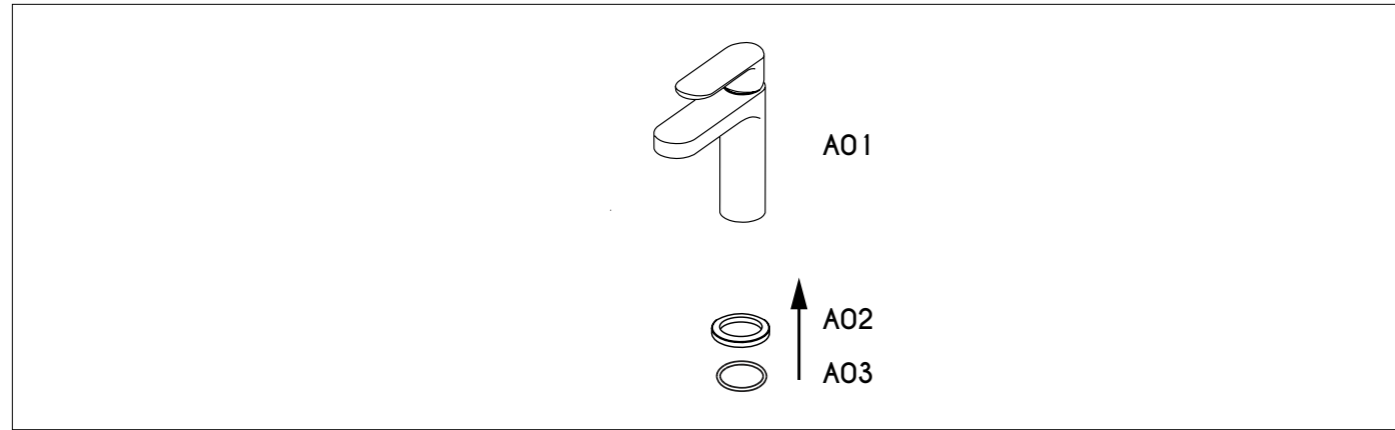

FUTUR BATH

www.futurbath.com